

**Service Manual
Model 181
Digital Nanovoltmeter**

**© 1981, Keithley Instruments, Inc.
October 1981, Cleveland, Ohio, U.S.A.
Document Number 30816**

Model 181 Service Manual Addendum

INTRODUCTION

This addendum to the Model 181 Service Manual is being provided in order to supply you with the latest information in the least possible time. Please incorporate these changes into the manual before servicing the Model 181.

Model 262 Low Thermal Voltage Divider

This addendum concerns availability of the Keithley Model 262 Low Thermal Voltage Divider, which is recommended for verifying accuracy and calibrating the Model 181 mV ranges. The Model 262 is a precision low thermal divider with divider ratios of $10^2:1$, $10^3:1$, $10^4:1$, and $10^5:1$. A low thermal male-to-male output cable is included with the Model 262. Note that Model 181 verification and calibration procedures that use the Model 262 are included in the Model 262 Instruction Manual.

Section 2, page 2-2:

Include the Model 262 Low Thermal Voltage Divider in the list of available accessories.

Table 3-1, page 3-1:

Replace Item B in the table with the Model 262.

Table 5-1, page 5-1:

Replace Items B and F with the Model 262.

TABLE OF CONTENTS

SECTION	TITLE	PAGE
1	General Information	1-1
1-1	Introduction	1-1
1-2	Warranty Information	1-1
1-3	Manual Addenda	1-1
1-4	Safety Symbols and Terms	1-1
2	Accessories	2-1
2-1	General	2-1
2-2	Model 1483 Low-Thermal Connection Kit	2-1
2-3	Model 1484 Refill Kit	2-1
2-4	Model 1485 Female Connector	2-1
2-5	Model 1486 Male Connector	2-1
2-6	Model 1488 Shorting Plug	2-1
2-7	Model 1503 Low-Thermal Solder and Flux	2-1
2-8	Model 1506 Input Cable	2-1
2-9	Model 1507 Input Cable	2-1
2-10	Model 1815 Maintenance Kit	2-2
2-11	Model 1019 Universal Rack Mounting Kit	2-2
3	Performance Verification	3-1
3-1	General	3-1
3-2	Recommended Test Equipment	3-1
3-3	Environmental Conditions	3-1
3-4	Performance Verification Procedure	3-1
3-5	Initial Conditions	3-1
3-6	DC Voltage Accuracy Check (2V to 1000V)	3-1
3-7	DC Voltage Accuracy Check (2mV to 200mV)	3-1
3-8	Hi Resolution Check	3-2
3-9	Damping Function Check	3-2
3-10	Filter Function Check	3-2
3-11	Noise Check	3-2
4	Theory of Operation	4-1
4-1	General	4-1
4-2	Power Supply	4-1
4-6	IEEE Standard Interface	4-1
4-7	Digital Section	4-1
4-8	Microcomputer Memory	4-2
4-9	A/D Converter Control	4-2
4-10	A/D Operation	4-3
4-11	Single Slope Phase	4-3
4-12	Serial/Parallel Conversion, Isolator Control	4-3
4-13	Clock Circuit	4-3
4-14	Display	4-4
4-15	D/A Converter	4-4
4-16	Nanovolt Preamp	4-4
4-17	Low Noise Design	4-4
4-18	Linearity and Gain	4-6
4-19	Feedback Elements	4-6
4-20	Offset Null	4-6
4-21	NMRR Filter and Buffer	4-6
4-22	Drift Correction	4-7
4-23	Input Protection	4-7
4-24	Input Mux Pumpout	4-8
4-25	FET Multiplexing	4-7
4-26	Input Mux	4-7
4-27	A/D Converter	4-8
4-28	Timing	4-8
4-29	Mux FETs	4-9
4-30	Transconductance Amplifier (GAMP)	4-9
4-31	Integrator	4-11
4-32	Reference Supply	4-11

TABLE OF CONTENTS
(CONTINUED)

SECTION	TITLE	PAGE
5	Maintenance	5-1
5-1	General	5-1
5-2	Recommended Test Equipment	5-1
5-3	Voltage Divider	5-1
5-4	Environmental Conditions	5-2
5-5	Calibration Procedure	5-2
5-6	Installation of the Calibration Cover	5-2
5-7	A/D Calibration (2V Range)	5-2
5-8	10Meg Adjustment	5-3
5-9	20V Range Adjustment	5-3
5-10	200V Range Adjustment	5-3
5-11	1000V Range Adjustment	5-3
5-12	D/A Calibration	5-3
5-13	Nanovolt Preamp Calibration	5-3
5-14	Troubleshooting	5-4
5-15	Special Handling of Static Sensitive Devices	5-4
5-16	Line Power	5-4
5-17	A/D Converter and Display	5-7
5-18	Display Board	5-9
5-19	Nanovolt Preamp Noise Troubleshooting	5-9
5-20	Preamp Noise Troubleshooting Checks	5-9
5-21	Checks of Preamp Zero	5-9
5-22	Buffer Check	5-12
5-23	Input Current Check	5-12
5-24	Bootstrap Check	5-12
5-25	Low Noise Supply Check	5-12
5-26	Current Bias Check	5-12
5-27	Input FET Replacement	5-12
5-28	Nanovolt Preamp Troubleshooting	5-13
5-29	DC Volts Attenuator Troubleshooting	5-13
5-30	IEEE Bus Circuit Troubleshooting	5-13
5-31	D/A Circuit Troubleshooting	5-13
5-32	Switch Input Section Troubleshooting	5-13
5-33	Digital Troubleshooting	5-15
6	Replaceable Parts	6-1
6-1	General	6-1
6-2	Ordering Information	6-1
6-3	Factory Service	6-1
6-4	Component Layouts	6-1
6-5	Schematics	6-1
	Appendix A	A-1

LIST OF ILLUSTRATIONS

FIGURE	TITLE	PAGE
1-1	Front Panel	1-2
1-2	Rear Panel	1-2
2-1	Model 1483	2-1
2-2	Model 1485	2-1
2-3	Model 1486	2-1
2-4	Model 1488	2-1
2-5	Model 1503	2-1
2-6	Model 1506	2-1
2-7	Model 1507	2-1
2-8	Model 1815	2-2
2-9	Model 1019	2 2
3-1	DCV Performance Check	3-1
3-2A	2mV and 20mV Performance Check	3-2
3-2B	200 Millivolt Performance Check	3-2
4-1	Latch Enable	4-2
4-2	A/D Control Logic	4-2
4-3	Charge Balance Timing	4-3
4-4	Single Slope Timing	4-3
4-5	Charge Balance-Single Slope Phase	4-4
4-6	Simplified Nanovolt Preamp Schematic	4-5
4-7	NVPA Showing Filter & Drift Correction	4-7
4-8	Preamp A/D Timing	4-8
4-9	V Range A/D Timing	4-9
4-11	Transconductance Amplifier	4-9
4-10	Simplified A/D Diagram	4-10
4-12	Integrator	4 11
4-13	Reference Supply	4-11
5-1	Shielded Enclosure	5-2
5-2	Connector Assembly	5-2
5-3	Male to Male Connector	5-2
5-4	Divider Connection	5-2
5-5	Preamp Calibration	5-3
5-6	DC Calibrator, Kelvin-Varley Divider and 181	5-4
5-7	Model 1815 Calibration Cover	5-5
5-8	480kHz Clock 1 μ sec/cm 2V/cm	5-9
5-9	2.4kHz Clock .2 μ sec/cm 2V/cm	5-9
5-10	Input Disable 10msec/cm 2V/cm	5-9
5-11	Input Disable 50msec/cm 2V/cm	5-9
5-12	AT101 Output 10msec/cm 2V/cm	5-9
5-13	Strobe Pulses 10msec/cm 2V/cm	5-9
5-14	AT103 Output 10msec/cm 2V/cm	5-10
5-15	AT104 Output 50msec/cm 2V/cm	5-10
5-16	V-F Output 10msec/cm 2V/cm	5-10
5-17	Integrator Output 10msec/cm .5V/cm	5-10
5-18	A/D Output Buffer Output 100msec/cm 5V/cm	5-10
5-19	Noisy Q413 10 μ V/cm 50ms/cm	5-11
5-20	Quiet Q413 10 μ V/cm 50ms/cm	5-11
5-21	Noisy U401 10 μ V/cm 50ms/cm	5-12
5-22	Quiet U401 10 μ V/cm 50ms/cm	5-12
6-1	Nanovolt Preamp PC-526, Component Location Diagram No. 30377D, Rev. C	6-15
6-2	Analog Board PC-529, Component Location Diagram No. 30503D, Rev. J	6-16
6-3	Display Board PC-530, Component Location Diagram No. 30532D, Rev. E	6-17
6-4	Digital Board PC-531, Component Location Diagram No. 30576D, Rev. J (sheet 1 of 2)	6-18
6-4	Digital Board PC-531, Component Location Diagram No. 30576D, Rev. J (sheet 2 of 2)	6-19
6-5	Nanovolt Preamp PC-526, Schematic Diagram No. 30586D, Rev. A	6-21
6-6	Analog Board PC-529, Schematic Diagram No. 30585D, Rev. C	6-23
6-7	Display Board PC-530, Schematic Diagram No. 30584D, Rev. C	6-25
6-8	Digital Board PC-531, Schematic Diagram No. 30583D, Rev. F (sheet 1 of 2)	6-27
6-8	Digital Board PC-531, Schematic Diagram No. 30583D, Rev F (sheet 2 of 2)	6-29

LIST OF TABLES

TABLE	TITLE	PAGE
3-1	Recommended Test Equipment for Performance Verification	3-1
3-2	DC Voltage Performance Check (2V to 1000V)	3-1
3-3	DC Voltage Performance Check (2mV to 200mV)	3-2
4-1	Microcomputer Memory Map	4-2
4-2	Gain Resistors	4-6
4-3	Gain Resistors for Volts	4-8
4-4	Mux FETs	4-9
5-1	Recommended Test Equipment	5-1
5-2	Voltage Divider Parts List	5-1
5-3	Power Supply Checks	5-6
5-4	A/D Converter	5-7
5-5	Display	5-8
5-6	Preamp Troubleshooting	5-13
5-7	DCV Attenuator Troubleshooting	5-13
6-1	Replaceable Parts List PC-531 Schematic 30583D	6-1
6-2	Replaceable Parts List PC-529 Schematic 30585D	6-6
6-3	Replaceable Parts List PC-526 Schematic 30586D	6-10
6-4	Replaceable Mechanical Parts	6-12
6-5	Cross Reference of Manufacturers	6-13

Section 1. General Information

1-1. INTRODUCTION.

The Keithley Model 181 is a 5½ and 6½ digit DC voltmeter with resolution to 10nV. The Model 181 is a unique DC voltmeter in the respect that it combines microprocessor technology for full programmability with a new concept in nanovolt front ends. It provides highly accurate, stable and low noise readings from 10nV to 1000VDC on 7 voltage ranges. The 2V through the 1000V ranges utilize the 5-way binding posts. The 2mV through the 200mV ranges utilize the special low thermal input connector.

The service manual contains the necessary information for calibrating and maintaining the Model 181. This information is provided in various sections throughout the manual. These sections are listed as Performance Verification, Theory of Operation and Maintenance/Calibration. Along with this section, General Information, this manual also includes the Accessories, a Parts List, and the Schematic Diagrams.

1-2. Warranty Information

The warranty is given on the inside front cover of this manual. If there is a need to exercise the warranty, contact the Keithley representative in your area to determine the proper action to be taken. Keithley maintains service facilities in the United

Kingdom and West Germany, as well as in the United States. Check the inside front cover of this manual for addresses.

1-3. Manual Addenda

Improvements or changes to the instrument which occur after the printing of this manual will be explained on a manual addendum.

1-4. Safety Symbols and Terms

This **WARNING** will be used throughout the manual whenever a danger exists that could result in personal injury or death. There is also an explanation of the potential danger that exists.

This **CAUTION** will be used throughout the manual whenever a hazard exists that could damage the instrument.

The symbol  on the instrument denotes that the user should refer to the operating instructions.

The symbol  on the instrument denotes that a hazard more may be present on the terminals.

DC VOLTS RANGE	5½-DIGIT RESOLUTION	ACCURACY ± (%rdg + digits)		TEMPERATURE COEFFICIENT ± (%rdg + digits)/°C 0°-18°C & 28°-35°C	INPUT RESISTANCE	MAXIMUM ALLOWABLE INPUT	NMRR (LINE FREQUENCY)
		24 HR., 22°-24°C	1 YR., 18°-28°C				
2mV	10 nV	0.006% + 5 d*	0.015% + 5d*	0.002 % + 3 d	> 1GΩ	120V**	> 90dB
20mV	100 nV	0.006% + 2 d*	0.015% + 2d*	0.002 % + 0.5d	> 1GΩ	120V**	> 80dB
200mV	1 μV	0.006% + 2 d	0.015% + 2d	0.002 % + 0.2d	> 1GΩ	120V**	> 80dB
2 V	10 μV	0.004% + 1.5d	0.007% + 2d	0.0007% + 0.2d	> 1GΩ	1000V	> 60dB
20 V	100 μV	0.004% + 1.5d	0.01 % + 2d	0.0008% + 0.2d	10MΩ	1000V	> 60dB
200 V	1mV	0.004% + 1.5d	0.01 % + 2d	0.0008% + 0.2d	10MΩ	1000V	> 60dB
1000 V	10mV	0.005% + 1.5d	0.01 % + 2d	0.0012% + 0.2d	10MΩ	1000V	> 60dB

CMRR: 160dB on mV ranges, 140dB on V ranges; at DC and line frequency (50 or 60Hz). (1kΩ unbalance)

*When properly zeroed.

**10 seconds maximum; 35V rms continuous

IEEE-488 BUS IMPLEMENTATION:

Multiline Commands: DCL, LLO, SDC, GET.

Uniline Commands: IFC, REN, EOI, SRQ, ATN.

PROGRAMMABLE PARAMETERS:

Front Panel Controls: Range, Filter, Zero, Damping, Hi Resolution.

Internal Parameters: SRQ Response, Trigger Modes, Data Terminators.

ADDRESS MODES: Talk-Only and Addressable.

TRIGGER MODES:

One Shot: Updates output buffer once at first valid conversion after trigger on TALK and/or GET.

Continuous: Updates output buffer at all valid conversions after trigger.

GENERAL

NOISE: Less than 30nV p-p on lowest range with Filter on.

INPUT CAPACITANCE: 5000pF on mV ranges.

SETTLING TIME: 0.5s to within 25 digits of final reading with Filter on, Damping off.

FILTER: 3-pole digital; RC = 0.5, 1 or 2 seconds depending on range.

CONVERSION SPEED: 4 readings/second.

DISPLAY: Seven 13mm (0.5 in.) LED digits with appropriate decimal point and polarity.

OVERLOAD INDICATION: Display indicates polarity and OFLO.

ANALOG OUTPUT:

Accuracy: ± (0.15% of displayed reading + 1mV).

Time Constant: 400ms.

Level: ± 2V full scale on all ranges; X1 or X1000 gain.

ISOLATION: Input LO to Output LO or power line ground: 1400V peak, 5 × 10⁵V•Hz, greater than 10⁹Ω paralleled by 1500pF

WARMUP: 1 hour to rated accuracy when properly zeroed.

ENVIRONMENTAL LIMITS: Operating: 0°C to 35°C, 0% to 80% relative humidity. Storage: -25°C to 65°C.

POWER: 105-125V or 210-250V (internal switch selected), 50-60Hz, 30V•A maximum.

INPUT CONNECTORS: Special low thermal for 200mV and lower ranges. Binding posts for 2V to 1000V ranges.

DIMENSIONS, WEIGHT: 127mm high × 216mm wide × 359mm deep (5" × 8½" × 14¼"). Net weight 3.85kg (8½ lbs.).

ACCESSORY SUPPLIED: Model 1506 Low Thermal Input Cable.

ACCESSORIES AVAILABLE:

Model 1019 Rack Mounting Kit

Model 1483 Low Thermal Connection Kit

Model 1484 Refill Kit for 1483 Kit

Model 1485 Female Low Thermal Input Connector

Model 1486 Male Low Thermal Input Connector

Model 1488 Low Thermal Shorting Plug

Model 1503 Low Thermal Solder and Flux

Model 1506 Low Thermal Input Cable (4 ft., Clips)

Model 1507 Low Thermal Input Cable (4 ft., Lugs)

Model 1815 Maintenance Kit

NOTES

1. NMRR specifications applies for input signals less than 120mV peak-to-peak on the 2mV and 20mV range, 1.2V peak-to-peak on the 200mV range and less than 2X full scale peak-to-peak on all other ranges. This is necessary in order to prevent A/D saturation.

2. ACCURACY SPECIFICATION

The accuracy specifications are defined exclusive of noise.

3. ZEROING

The term "when properly zeroed" means rezeroing during warmup (first 4 hours) and after ambient changes in temperature of greater than 1°C.

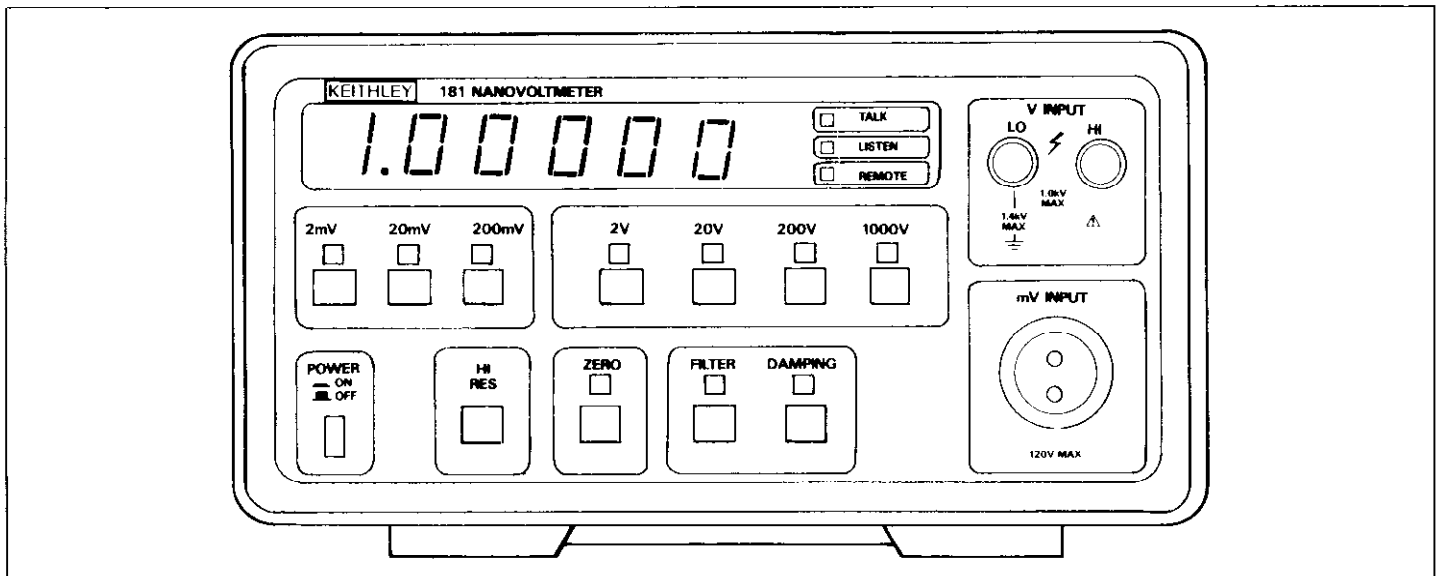

FIGURE 1-1. Front Panel

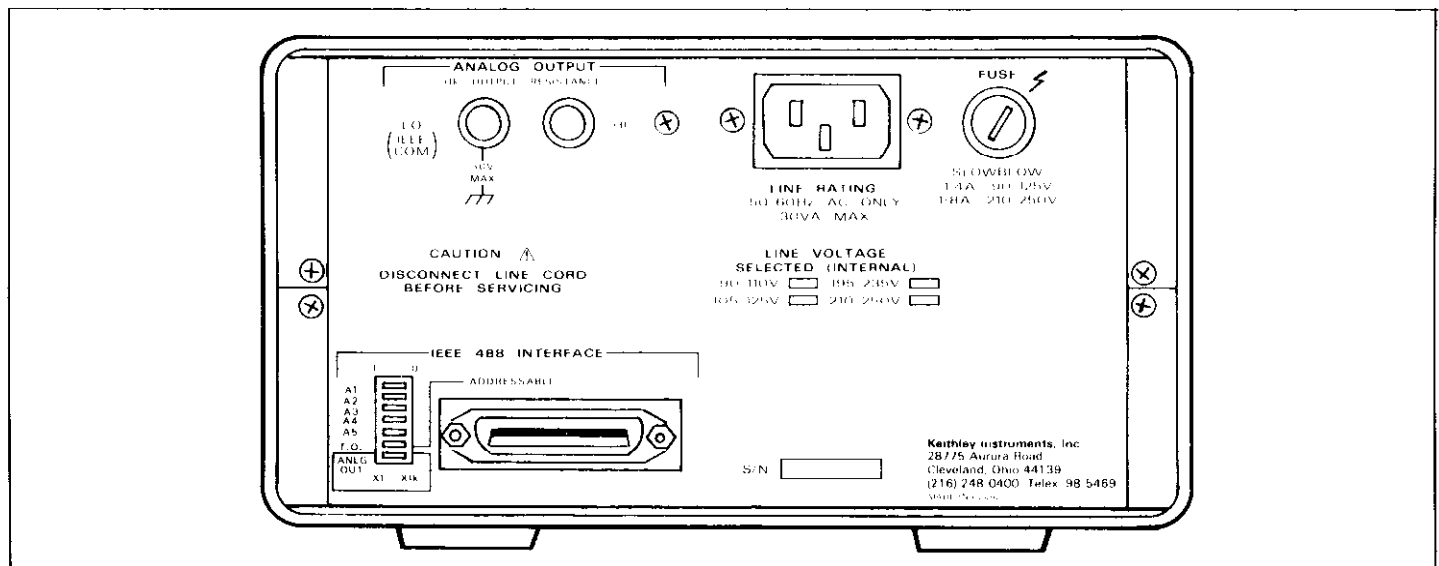

FIGURE 1-2. Rear Panel

Section 2. Accessories

2-1. GENERAL

This section describes the various accessories and options available for use with the Model 181.

2-2. Model 1483 Low-Thermal Connection Kit. The Model 1483 Kit contains a crimp tool, shielded cable, an assortment of copper lugs, copper wire, cadmium solder and nylon bolts and nuts. It is a complete kit for making very low thermal measuring circuits. The kit enables the user of the Model 181 to maintain the high thermal stability of the nanovoltmeter in his own application.

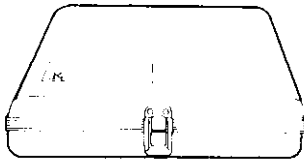

Figure 2-1. Model 1483

2-3. Model 1484 Refill Kit. The Model 1484 Refill Kit contains replacement parts for the 1483 Kit. It contains copper lugs, cleaning pads, splice tubes, alligator clips, 10-foot shielded cable, a spool of copper wire, nylon screws and nuts and 10 feet of cadmium solder.

2-4. Model 1485 Female Connector. The Model 1485 Low Thermal connector is to be used with the Model 1481, 1482 or the 1486 for constructing low-thermal, shielded connections to the low voltage circuits.

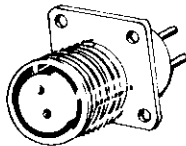

Figure 2-2. Model 1485

2-5. Model 1486 Male Connector. The Model 1486 Low-Thermal Connector is a mating connector for the Model 1485. The Model 1486 contains gold plated tellurium copper pins. This connector is specially manufactured by Keithley Instruments. It can be used to construct a custom length low-thermal cable to connect the 181 to the particular measurement set up.

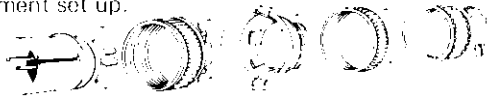

Figure 2-3. Model 1486

2-6. Model 1488 Shorting Plug. The Model 1488 is useful for checking proper operation and for calibrating the Model 181. Its electrical and thermal construction minimizes errors caused by thermal EMFs. The Model 1488 is very useful for checking the Model 181's offset and drift.

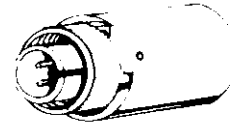

Figure 2-4. Model 1488

2-7. Model 1503 Low-Thermal Solder and Flux. Model 1503 consists of flux and 4 ounces of cadmium solder. It is used to solder connections for low voltage measurements.

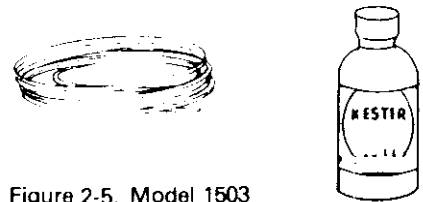

Figure 2-5. Model 1503

2-8. Model 1506 Input Cable. The Model 1506 is a triaxial 1.2M (4 ft.) cable designed to provide excellent shielding for the sensitive input connections to the Model 181. It has a low thermal connector and two copper alligator clips. One Model 1506 is supplied with every 181.

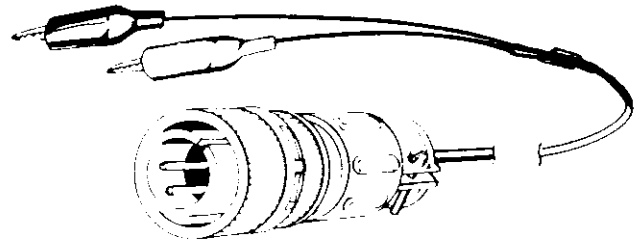

Figure 2-6. Model 1506

2-9. Model 1507 Input Cable. The Model 1507 is a triaxial 1.2M (4 ft.) cable. It is similar to the Model 1506 but is terminated with copper spade lugs.

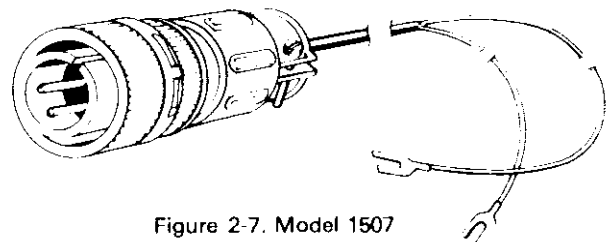

Figure 2-7. Model 1507

2-10. Model 1815 Maintenance Kit. The Model 1815 is a Model 181 Maintenance Kit that consist of a Calibration Cover and two Extender Cables. The Calibration Cover is necessary to stabilize internal temperature when calibrating the Model 181. It also can be used to locate adjustments quickly and easily. The two extender cables permit easy access to the individual PC boards contained in the Model 181.

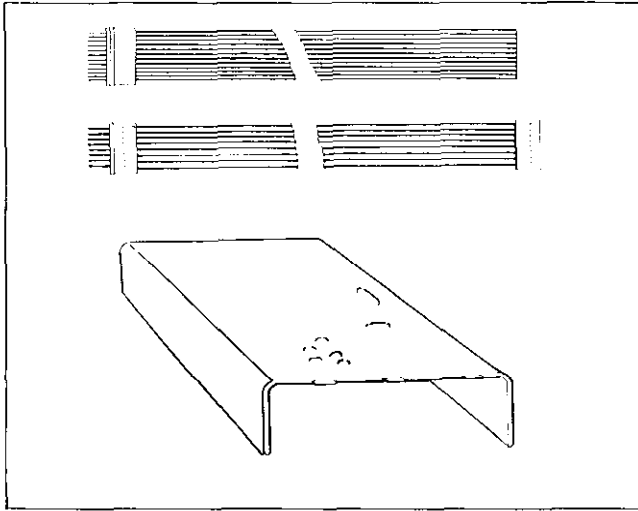

Figure 2-8. Model 1815

2-11. Model 1019 Universal Rack Mount Kit. The Model 1019 is a single/dual rack mounting kit for the Model 181. The overall dimensions are 5¼ inches (133mm) high and 19 inches (483mm) wide.

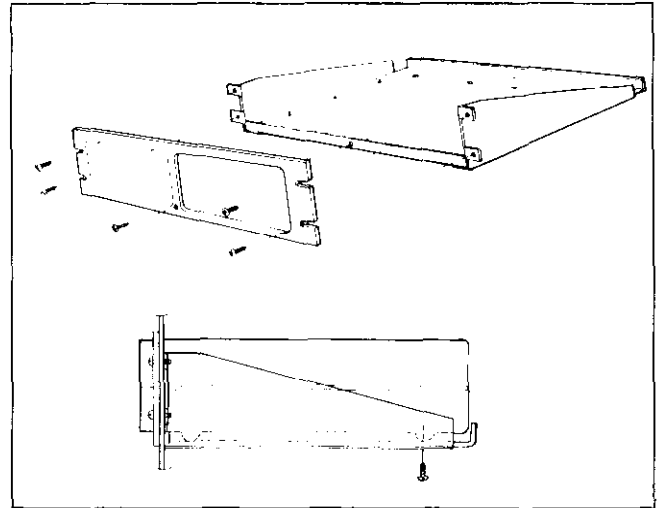

Figure 2-9. Model 1019

Section 3. Performance Verification

3-1. GENERAL

Performance verification may be done upon receipt of the instrument to ensure that no damage or misadjustment has occurred during transit. Verification can also be performed whenever there is question of the instrument's accuracy, and following calibration, if so desired.

NOTE

For instruments that are still under warranty (less than 12 months since date of shipment), contact your Keithley representative or the factory immediately if the instrument falls outside of specifications as determined by the Performance Verification in paragraph 3-6.

3-2. Recommended Test Equipment

Recommended test equipment for performance verification is listed in Table 3-1. Alternate test equipment can be used. However, if the accuracy of the alternate test equipment is not at least three times better than the instrument specifications, additional allowances must be made in the readings obtained.

TABLE 3-1
RECOMMENDED TEST EQUIPMENT FOR
PERFORMANCE VERIFICATION

Item	Description	Specifications	Mfr.	Model
A	DC Calibrator	001% 10ppm	Fluke	332D
B	Kelvin-Variety Divider	+ 0.1ppm	Fluke	720A
C	Low-Thermal Cable	Low Thermal EMFs	Keithley	1506

3-3. Environmental Conditions

All measurements should be made at an ambient temperature within the range of 18°C to 28°C (65°F to 82°F), and a relative humidity of less than 80%.

3-4. Performance Verification Procedure

Use the following procedure to verify the basic accuracy of the Model 181 for DC voltage. If the instrument is out of specification at any point, perform a complete calibration as described in the calibration section unless the instrument is still under warranty, as noted above.

CAUTION

The performance verification and all service information is intended for qualified personnel using accurate and reliable test equipment.

WARNING

Some procedures require the use of high voltage. Take care to prevent contact with live circuits which could cause electrical shock resulting in injury or death.

3-5. Initial Conditions

Before beginning the verification procedure, the instrument must meet the following conditions:

If the instrument has been subjected to extremes of temperature, allow sufficient time for internal temperatures to reach environmental conditions

specified. Typically, it takes one hour to stabilize a unit that is 10°C (18°F) out of the specified temperature range. It takes approximately four hours warm up for optimum drift performance.

3-6. DC Voltage Accuracy Check (2V to 1000V Range)

CAUTION

Do not exceed maximum allowable input voltage. Instrument damage may occur. Maximum allowable input is stated in the specifications.

- Dial the DC calibrator to 0000000 and connect it to the two five-way binding posts on the Front Panel of the 181.
- Select the appropriate range as given in Table 3-2. Select the range manually by pressing the appropriate front panel button or select the range automatically by issuing the appropriate command over the bus.
- Zero the 181 by pressing the ZERO button on the Front Panel or by issuing the appropriate command over the bus.
- Set the calibrator to the value given in Table 3-2. Select each range and apply the required voltage as specified in Table 3-2. Verify that the displayed reading is within the Allowable Reading. Note the readings obtained on each range.
- Set the DC calibrator to 0000000.
- Reverse the input leads.
- Zero the 181 by pressing the ZERO button on the Front Panel or by issuing the appropriate command over the bus.
- Repeat Step D. Verify that the displayed reading is the same as in Step D \pm 3 digits.

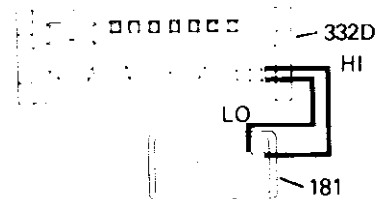

Figure 3-1. DCV Performance Check

TABLE 3-2
DC VOLTAGE PERFORMANCE CHECK
(2V to 1000V)

Range	Applied Voltage	Allowable Reading at 18°C to 28°C
2V	1.90000V	1.89985 to 1.90015
20V	19.0000V	18.9979 to 19.0021
200V	190.000V	189.979 to 190.021
1000V	1000V	999.84 to 999.16

3-7. DC Voltage Accuracy Check (2mV to 200mV)

CAUTION

Do not exceed maximum allowable input voltage. Instrument damage may occur. Maximum allowable input is stated in the specifications.

- A. Obtain a low thermal cable and divider box as described in Section 5.
- B. Connect the low thermal cable between the 181 and the divider box.
- C. Connect the DC calibrator as shown in Figure 3-2A. For the 2mV and 20mV ranges. Allow a few minutes for thermal FMF's to settle out. Use Figure 3-3B for the 200mV range.
- D. Set the DC calibrator for 0000000 output
- E. Select the appropriate range as given in Table 3-3. Select the range manually by pressing the appropriate Front Panel button or select the range automatically by issuing the appropriate command over the bus.
- F. Zero the 181 by pressing the ZERO button on the Front Panel or by issuing the appropriate command over the bus.
- G. Apply the required voltage as specified in Table 3-3. Verify that the displayed reading is within specifications. Note the reading.
- H. Repeat steps D through G on the remaining mV ranges.
- I. Reverse the polarity of the source and set it to 0000000 output.
Rezero the 181 by pressing the ZERO button twice.
- K. Apply the input as in step G. Verify the displayed reading (with opposite polarity) is the same as in step G ± 3 digits

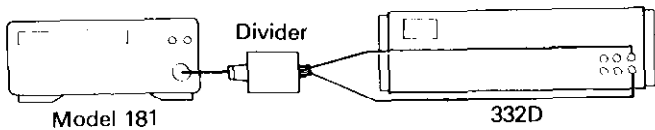

Figure 3-2A 2mV and 20mV Performance Check

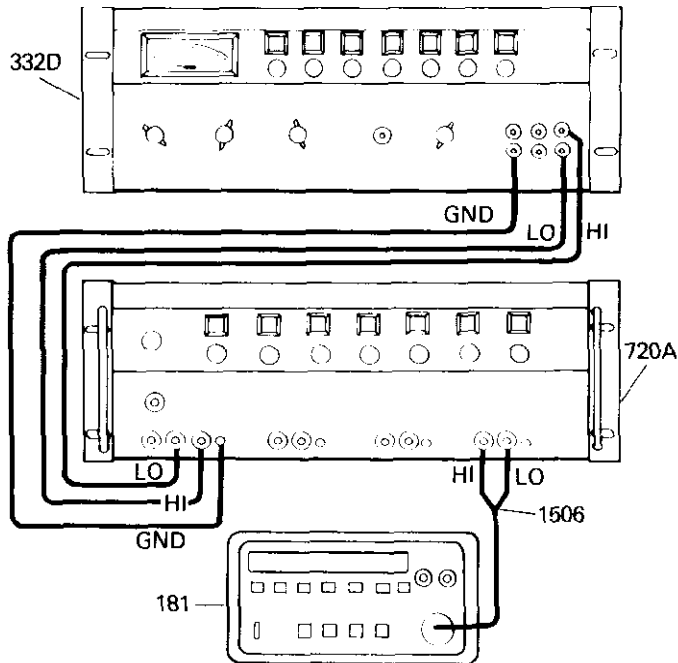

Figure 3-2B. 200 Millivolt Performance Check

TABLE 3-3
DC VOLTAGE PERFORMANCE CHECK

Range	Applied Voltage	Allowable Reading at 18°C to 28°C
2mV	1.90000mV	1.89967 to 1.90033
20mV	19.0000mV	18.9970 to 19.0030
200mV	190.000mV	189.970 to 190.030

3-8. HI RESOLUTION Check

Upon power up, the 181 will be in the 5 1/2 digit mode of resolution (B0). To check the HI RES function proceed as follows:

- A. Short the volts LO and HI together. Press the ZERO button on the Front Panel. This will obtain a stored baseline.
- B. Apply the signal and the displayed reading will equal the difference between the stored baseline and the input signal.
- C. Press the ZERO button again and the reading that will be displayed is rough. Rough data is different from the reading obtained in Step B because rough data will include the signal and various offsets. When offsets equal the stored baseline, the two readings will be the same. By seeing a difference between rough data and Step B, this will confirm that the ZERO function is operating properly.

3-9. DAMPING Function Check

Upon power up, the DAMPING function is off (D0). To check to see that the DAMPING function is operating properly, use the following procedure:

- A. Select 2V range.
- B. From a zero reading apply a Full Scale signal and observe the settling time.
- C. Press the DAMPING button to turn the function on. From a zero reading apply a Full Scale signal and observe the settling time.
- D. The settling time will be longer with DAMPING on. This difference will reveal that the DAMPING function is operating properly.

3-10. FILTER Function Check

Upon Power up the Filter function is disabled (PI). To check to see that the FILTER is operating properly use the following procedure:

- A. Select 2V range.
- B. Press the DAMPING button and then from a zero reading apply a Full Scale signal. Observe the settling time.
- C. With DAMPING on press the FILTER button. From a zero reading apply a Full Scale signal. Observe the settling time.
- D. The settling time will be longer with the FILTER enabled. This difference reveals that the FILTER is operating properly. This procedure will only work when DAMPING is on.

3-11. NOISE Check

Noise is defined (on lowest range) as peak-to-peak excursion over a period of two minutes, tested after warmup while the input is shorted with the Model 1488.

Procedure for checking noise:

- A. Short the mV input with a Model 1488 Low Thermal Short.
- B. Select the 2mV range.
- C. Turn on HI RES so that 6½ digits are displayed.
- D. Depress Filter button.
- E. Depress ZERO button. Observe the highest and lowest readings for a period of 2 minutes. The difference should be less than 30 counts (30nV p-p).

Section 4. Theory of Operation

4-1. GENERAL

This section contains in-depth discussions of the major circuit blocks, which are listed below:

- A. Power Supply (included on Motherboard) PC-531, page 6-27.
- B. IEEE Standard Interface (included on Motherboard) PC-531, page 6-27
- C. Digital Section (included on Motherboard) PC-531, page 6-27.
- D. Display (Display Board) PC-530, page 6-25.
- E. D/A Converter (Motherboard) PC-531, page 6-27.
- F. Nanovolt Preamp (Nanovolt Preamp Board) PC-526, page 6-21.
- G. A/D Converter (Analog Board) PC-529, page 6-23.

There are several figures and tables provided with each major circuit block that will aid in their explanation.

4-2. Power Supply

While studying the theory of operation for the Power Supply, it will be helpful to refer to the Schematic Diagram 30583D, Sheet 1 of 2.

4-3. The AC power is brought into the 181 by a recessed line plug J1011. Fuse F101 and line plug J1011 are located on the rear panel. Switch S101 is the main power switch and it is located on the Front Panel. Switch S102 is the 115V to 230V configuration switch and is located internally.

4-4. The regulated portion of the 181 power supply is sectioned into six different supplies. There are three supplies (+15V, -15V, +5V) for the analog section of the 181. The other three supplies (+15V, -15V, +5V) are for the digital section of the 181.

The key to the Analog/Digital isolation is the split bobbin transformer T101. The digital supply winding, along with the primary windings, are at the bottom half of the bobbin, and the analog supply windings are located at the top of the bobbin.

4-5. The six supplies operate from four separate windings of transformer T101. The four windings are fed into four full wave bridge rectifiers: Two rectifiers for the analog section CR105 and CR106 and two rectifiers for the digital section CR104 and CR107. Capacitors C128, C123, and C127 bypass regulators U128 (5V), U129 (+15V) and U130 (-15V) respectively. These are the analog supplies.

Capacitors C134 and C135 filter the input voltage to U136 and U137 respectively. Capacitors C132 and C133 bypass regulators U136 and U137 respectively. Capacitor C130 filters the output of CR104. Regulator U135 receives its input from the regulated output of U136. Q103 and Q105 are configured as a high current gain voltage regulator. Q104 completes the unity gain loop by compensating the V_{BE} drop of Q103. CR101 provides short circuit limiting to the circuit.

4-6. IEEE Standard Interface

While studying the theory of operation of the IEEE Standard Interface, it will be helpful to refer to the Schematic Diagram 30583, sheet 1 of 2.

The entire IEEE Interface circuitry is located on the mother board. The Standard Bus Connector is located on the rear panel. The primary address switches are located next to the Bus Connector. The primary address switches not only select the primary address, but they also permit selection of 31 primary talker/listener address pairs. Binary 11111 is reserved for Untalk and Unlisten commands. To address the 181, the IEEE-488 controller must send the primary address of the 181.

NOTE

The primary address is updated only upon power up

In reference to the Schematic Diagram 30583D, it is clear that U131 is the heart of the IEEE chip which is capable of performing all IEEE Talk/Listen protocols. The data lines are D0 through D7. The tri-state IEEE Bus buffers U133 and U134 are used to drive the output. The data is buffered by U133 and U134, and is transmitted to the Bus by connector J1006. The thick film resistor network R131 provides the necessary pull up resistors for the primary address switch bank S103. The processor reads these switches and then knows which Talker and Listener address to assign the 68488 chip and thus the 181. This section is accessed with ASE. This signal is derived from the 68488 chip and enables the tri-state buffer U132, placing the address on the data bus (D0 - D5).

4-7. Digital Section

During the theory of operation of the digital section, it will be helpful to refer to the Schematic Diagram 30583D, Sheet 1 of 2. The digital section of the 181 has a power on reset circuit which resets processor U109, the versatile interface adapter VIA (U110) and the IEEE chip U131 upon power up to insure proper system operation. The Reset line provides a 20 millisecond pulse upon power up to get the dynamic buffers and clock of the processor running properly. The Reset circuit consists of U105, U106, R103, R134, C103, and C105. There are two inputs to this circuit: the 2.4kHz clock and the Latch Enable. The 2.4kHz clock is counted by U105, and Latch Enable is used to clear U105. Refer to Figure 4-1. In normal operation, Latch Enable pulses low for 1 microsecond every 833 microseconds (1.2kHz rate). The display multiplexing is the same rate as this. The voltage on capacitor C105 rises exponentially while Latch Enable is LO. A clear pulse is applied to U105, and the CLEAR line to the microprocessor remains HI when Latch Enable returns to HI and while the voltage on C105 is above the threshold of NAND gate U106B. Therefore, normally U105 accumulates a few counts and is cleared. A transient can mask the Latch Enable pulses, or a lost program can prevent their appearance at all. If not, Latch Enable pulses occur for 53.3 milliseconds, 128 counts will be allowed to accumulate in U105 and its output will go HI. The U105 output is inverted by U106D and resets the microprocessor and the VIA. The Reset line is held LO for 53.3 milliseconds, which is greater than the required minimum (20 milliseconds). This assures proper reset.

R103 and C138 make up a delay circuit that provides a reset delay of 3 milliseconds which permits the reset circuit to ignore any transient which does not affect the microprocessor or program execution.

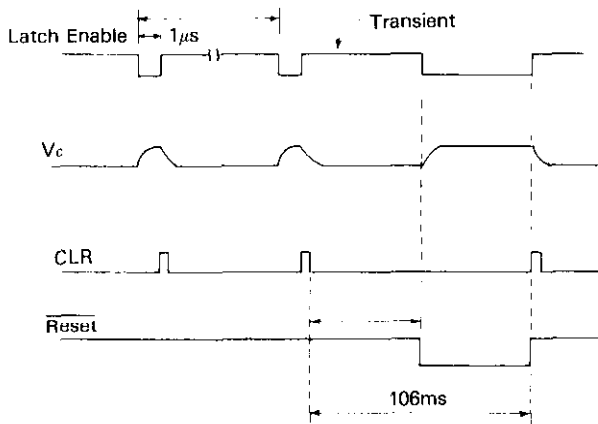

FIGURE 4-1. Latch Enable

4-8. Microcomputer Memory

The microcomputer utilized in the 181 uses partial memory decoding. The address lines A11, A12, A14 and A15 determine whether the EPROMS (U102 and U103), VIA (U110), IEEF 488 (U131), RAM (U108) or switch port is selected for use. Direct memory addressing can be utilized because the 6810 (U108) and 6802 (U109) RAM are located in the lower 256 bytes. When A12, A14, and A15 are a logic "1" and the EPROMS are selected, A11 determines which of the two EPROMS is enabled. The lower 2^k bytes of program memory are contained in EPROM U103; the upper 2k bytes of program memory are located in EPROM U102. The program contained in these two chips is actually located in D000-DFFF. However, it also appears to the microprocessor at F000-FFFF because of the partial memory decoding mentioned earlier. This permits the Vectors to be decoded at FFF7 to FFFF.

TABLE 4-1
MICROCOMPUTER MEMORY MAP

Hex Address	Contents
FFFF - FFFF	Restart Vector
FFFC - FFFD	NMI Vector (not used)
FFFA - FFFB	Software Interrupt Vector
FFF8 - FFF9	IRQ Vector
D000 - DFFF	Program Memory
C800	Switch Port
8000 - 8007	IEEF-488
4000 - 400F	VIA
0080 - 00FF	6810 RAM
0000 - 007F	6802 RAM

4-9. A/D Converter Control

During the theory of operation of the A/D converter control, it will be most helpful to refer to the Schematic Diagrams

30583D, Sheet 2 of 2 and 30585D. The digital control circuits of the 181 A/D are located on Schematic 30583D, Sheet 2 of 2 while the circuits that they control are located on Schematic 30585D.

The conversion from analog data to digital data begins with the integration cycle. Refer to Figures 4-3 and 4-4. An integration cycle begins with the appropriate signals to the input amplifier and preamplifier enabled by one or more of the S1 thru S12 lines going to a logic "1". The charge balance line will go to a logic "1" after the microprocessor waits for the input to settle. The "D" input of U122A also goes to a logic "1" and is gated to U123B through U127B. This clears the 16 bit counter U123B. The Q output of U122A will enable the input signal to the integrator on the next rising edge of the 2.5kHz clock. The microprocessor waits 16.66 milliseconds (the integration period for 60Hz, 20.00 milliseconds for 50Hz) then the charge balance start line goes to logic "0". At the next rising edge of the clock, the Q output goes to a logic "1" again. This will disable the input to the integrator and ends the exact 16.66 millisecond integration period.

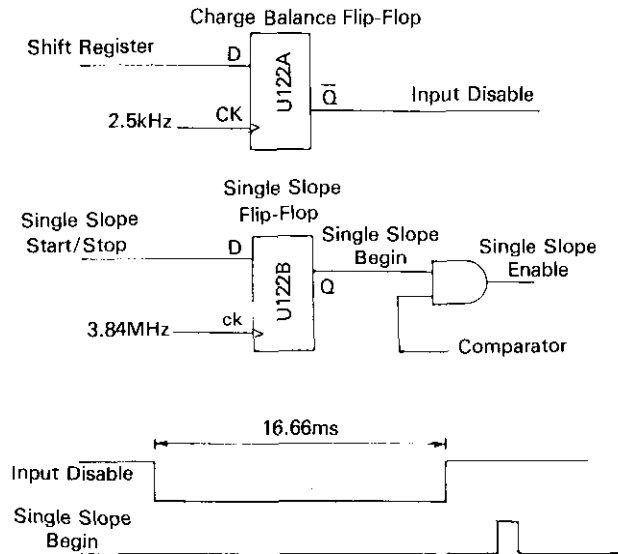

FIGURE 4-2. A/D Control Logic

While the integration period is taking place, pulses from the V-F are inputted into the 16-bit counter U123B. When the counter overflows after 16 counts, clock pulses are generated which the VIA counts in an internal counter. These clock pulses become the most significant bits of the result.

24-Bit Result

- 8 Bits** - These bits are generated by clock pulses during the Charge Balance phase.
- 4 Bits** - This is the remainder left on the 16-bit counter during the CB phase.
- 8 Bits** - These counts are accumulated in the 16-bit counter during the single slope phase.
- 4 Bits** - This is the remainder left on the 16-bit counter during the single slope phase.

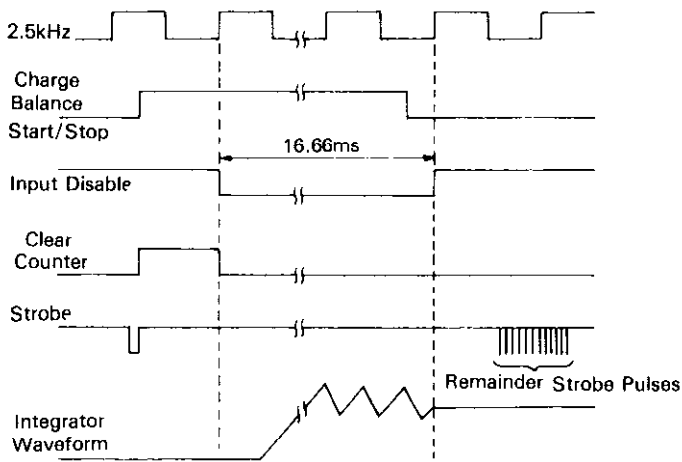

Figure 4-3. Charge Balance Timing

At the end of a charge balance phase, 4 bits of data are left on the 16-bit counter. This data is obtained by setting the remainder line to "1" and strobing the counter and waiting for the counter to overflow. The number left on the counter is equal to 16 minus the number of strobe pulses. This data now becomes the next 4 bits of the 24-bit result.

The single slope phase begins with the Single Slope Start line setting the "D" input of U122B to "1". On the next rising edge of the 3.84MHz clock it is now inputted to the 74LS393 where it is counted, similar to the charge balance phase. The single slope phase ends when the comparator goes to "0" and gates off the 3.84MHz clock from the counter. The remainder left on the counter is again read as in the charge balance phase. This result is added to the charge balance counts to generate the 24-bit result.

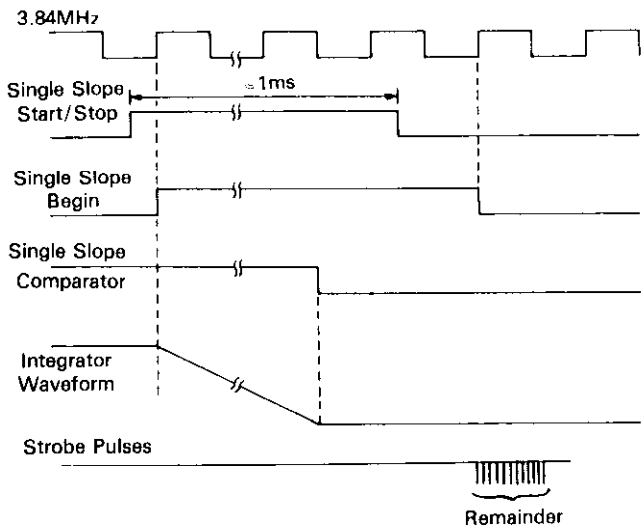

FIGURE 4-4. Single Slope Timing

4-10. A/D OPERATION

The A/D operates in two phases; first the charge balance phase (CB), and the single slope phase (SS). Figure 4-5 shows

Charge Balance Phase: A CB phase is started at t = 0 when the input disable is released, connecting I_i to the integrator and V_O ramps positive. The D flip flop acts as a comparator and provides timing and control. After V_O exceeds the D threshold of U301A, Q1 goes high at a positive going clock edge.

At the next clock edge (negative going), Q2 goes high and connects I_{CB} to the integrator. I_{CB} is greater than 2•I_{SS} maximum so that V_O immediately ramps negative. Q2 is low at this time which set and holds Q1 low. At the next negative going clock edge (1 cycle later) Q2 goes low again, turning off I_{CB} and enabling D1. What has happened is that I_{CB} was turned on for one clock cycle (2 microseconds) and then was turned off. The earliest it can turn on again is one clock cycle later. Each time I_{CB} is turned on, the counter is incremented by Q2. The input is disabled after precisely 16.67 milliseconds. In this time interval there were 8000 480kHz clock cycles and the maximum number of times Q2 could go high and be counted was 4000. This concludes the Charge Balance Phase.

4-11 Single Slope Phase

At the end of the Charge Balance Phase, the output of the integrator is resting at some positive voltage. Then, the Single Slope Enable line is energized. This causes I_i to flow into the integrator. The single slope comparator output is also positive and it will not switch until the integrator output crosses zero. A 3.84MHz clock is counted from when the Single Slope Enable is energized until the Single Slope Comparator changes state (V_O crosses zero). When this occurs, Single Slope Enable is shut off and the counting process is stopped. Because of the ratios of I_{CB}/I_{SS} and the clock ratios, one charge balance count is weighted as 1024 single slope counts. This gives a composite count of 4 096 million.

4-12 Serial/Parallel Conversion, Isolator Control

One of the many functions of the VIA is to transfer data from the digital side to the analog side of the optical isolators. With the strobe line (PB7) HI, a data transfer starts. One byte of data is stored in the serial register (SR) of the VIA and automatically clocked through the optical isolators using the clock (CB1) and data (CB2) lines of the serial port. Another eight bits of data are sent in a similar fashion. The strobe line (PB7) is brought LO then HI again to latch the data into the output of these registers.

4-13 Clock Circuit

The 3.84MHz clock is a Pierce oscillator using Q101 as the gain element and a 3.84MHz crystal Y101 as the feedback element. L101 and C119 act as a parallel resonant load. R124, R125, and C122 provide appropriate level-shifting compatible with the TTL input of U127C. The output of U127C provides a buffered TTL compatible 3.84MHz clock with U123A which runs the charge balance circuitry within the A/D. The 2.4kHz clock is obtained by further dividing the 3.84MHz clock with U123A and U125. This clock is used to provide an exact 16.66 millisecond or 20 millisecond window, and provides the interrupts for the microprocessor and the reference timing for the Reset and Transient Recovery circuit.

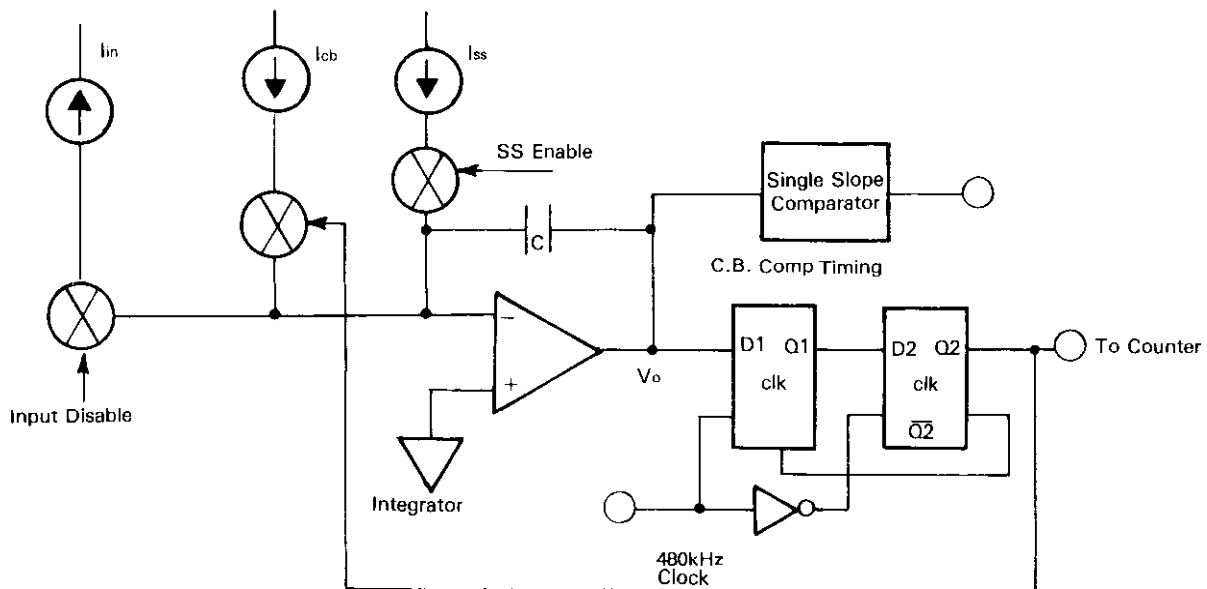

FIGURE 4-5 Charge Balance - Single Slope Phase

4-14 Display

During the theory of operation of the Display, it will be helpful to refer to the Schematic Diagram 30584D.

The display information is outputted on PA0 through PA7 on the VIA (I/O) bus. The information is updated at a 1.2kHz rate which means each digit is on for 833 microseconds. Each update begins by presenting new segment information on the VIA (I/O) bus (PA0 - PA7) and outputting a clock pulse on CA2. The clock pulse goes to U203, which is a shift register on the display board. U203 shifts a digit enable bit to the next digit to be enabled. Every eight times the display is updated, a digit enable bit is generated at PB5 and goes to the enable data input of the shift register.

V201C, V202B and V202C drive the rows of the switch matrix. The switches are arranged in a 4 by 4 matrix, eleven of which are used. The columns of the switch matrix go to Bits 0-3 of the switch port.

The switch port is located on the motherboard in Schematic 30583D, Sheet 2 of 2, Section F5. The segment drivers are Q201-Q208. In addition to driving the various segments, they also activate the appropriate LED's.

4-15. D/A Converter

The heart of the D/A section is U117, shown on Schematic 30583D, Sheet 1 of 2. It is a standard 12-bit D/A converter. Data for the D/A is multiplexed with the display data and is latched into U116. This data is converted into an output current. U118 is configured as a current-to-voltage converter. Capacitor C110 compensates for output capacitance of U117. The output voltage from U118 swings from 0V to -10V, since output current flows through RF which is internal to U117 (AD7541). All bits off yields 0V output at U118; all bits ON yields -10V output at U118.

VR102 is configured as a reference for the D/A circuit. R107, R108, R109 and U119B scale the reference to +10V. R107 provides an adjustment range on the +10V reference which calibrates positive Full Scale. An offset for U119A is provided by R111, R112, R106 and VR102. This offset plus R113 and R114 provide the scaling which translates the 0V to -10V swing (output of U118) to the desired -2 to +2V swing. R106 calibrates negative full scale by altering the offset voltage on U119A.

Capacitor C137 filters the output and prevents it from appearing like a staircase waveform. VR103, VR104 and R130 are configured as protection in case the analog output terminals should be momentarily shorted together or tied to greater than $\pm 30V$.

4-16. Nanovolt Preamp

During the theory of operation of the Nanovolt preamp, it will be helpful to refer to the Schematic Diagram 30856D.

4-17. Low Noise Design

One of the major reasons for utilizing a differential input stage is the Supply Noise Rejection. Without proper matching, power supply noise would have to be on a submicrovolt level which would be impossible at low frequencies. Both bias current noise and voltage noise are the major components of Supply Noise. In order to minimize voltage noise, a pair of low noise bipolar supplies are generated on the Nanovolt Preamp board using U405 and its associated components. VR403 and VR404 serve as references (6.2 volts) and R421, R422 and R413 scale the output voltages ($\pm VR$) to the desired ± 10 volt level. By providing the attenuation above 0.3Hz, C412 and C413 prevent amplification of U405's input voltage noise. U404A bootstraps these supplies to improve amplifier linearity. The noise contribution from reference zeners VR403 and VR404 is

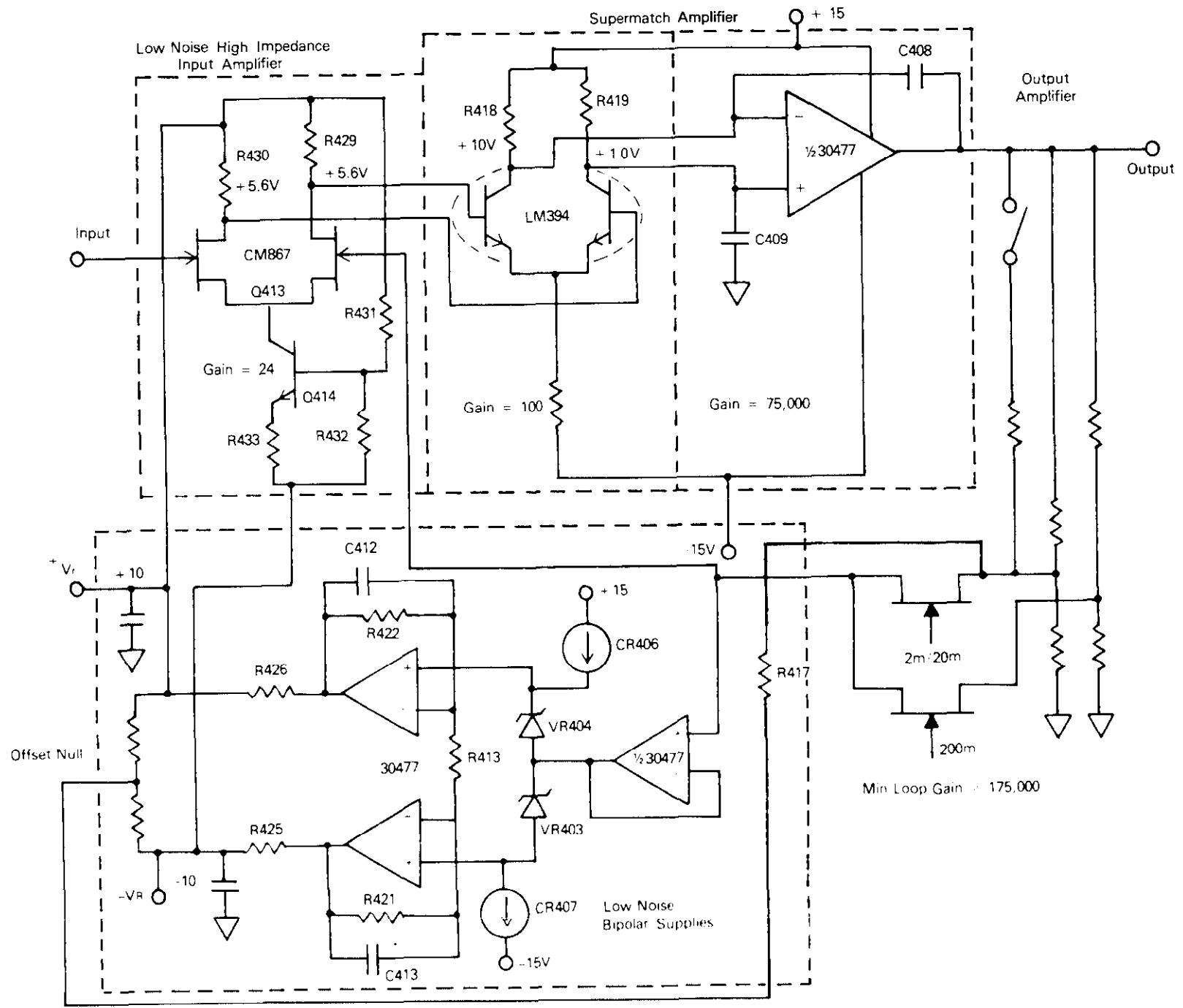

FIGURE 4 - 6. Simplified Nanovolt Preamp Schematic

negligible. The bootstrap supply is decoupled from the input via C414, C415, R425 and R426. Rejection from the $\pm 15V$ supplies is critical as well. Therefore, current regulators CR406 and CR407 are a necessity ($R_p > 1M \text{ ohm}$) since R_s of VR403 and VR404 is approximately 100 ohms.

The key to maintaining low current noise in the drain circuit of Q413 is the selection of a low noise, high gain device for Q414 and maintaining low emitter and base impedances over the bandwidth. R431, R432 and R433 provide bias for Q414 and are referenced to $\pm V_R$ for low noise contribution.

Noise contribution from the second stage depends upon drain loads of Q413, gain of the first stage and input noise of the second stage. Q412 is a precisely matched low noise amplifier transistor pair which act as the second stage for the 181 preamp. In addition to low noise, this transistor pair (Q412) is required because of its high CMRR performance.

4-18. Linearity and Gain

In a differential DC amplifier, nonlinearities in the input stage provide the limitation to gain linearity under the closed loop condition. In fact, no amount of loop gain can cancel these nonlinearities. The input FETs are square law devices which means the output current varies as the square of the V_{GS} . In order to cancel this nonlinearity, a second FET is used as a load to the first FET (differential pair). The degree of linearity depends upon the matching between the two devices.

The total amplifier loop gain must be kept high so that closed loop gain is independent of open loop gain. This eliminates problems with gain drifts due to time/temperature variations inside the loop. To maintain stable closed loop gains of 1000 (2mV range), 100 (20mV range) and 10 (200mV range) appropriate film or wirewound resistors are chosen as feedback elements. Refer to Table 4-2.

TABLE 4-2
GAIN RESISTORS

Range	Gain Resistors	Gain	Adjustment
2mV	R409, R414, R435	1000	R409
20mV	R410, R415, R435	100	R410
200mV	R411, R416, R434	10	R411

The 20mV adjustment depends slightly on 2mV gain. Thus, 2mV gain should be adjusted before the 20mV adjustment is completed. The 200mV adjustment is independent of all others. FET Q418 selects the 2mV and 20mV legs. FET Q417 selects 20mV leg. Relay K401 selects 20mV.

4-19. Feedback Elements

Thermal drifts in the input amplifier are relatively unimportant since they are autozeroed out. Slowly varying drift components (such as solder joints, reed relay contacts) are of little significance. Therefore, no special low-thermal terminals are necessary in the feedback loop.

However, for the nanovolt ranges (2mV, 20mV), it is necessary to use wirewound resistors wherever low voltage signals are present. This is why R435 is a wirewound element, whereas R434, R409-R416 are film resistors. Film resistors display much higher voltage noise whereas wirewounds are available whose noise approaches theoretical limits. R435 is selected as 200 ohms since the Johnson noise of this value is negligible compared to amplifier noise.

4-20. Offset Null

The input FET match provides 25mV differential offset voltage referred to the amplifier input. Since this differential is auto zeroed out by drift correction circuitry (which will be discussed later) and the A/D, it is only necessary to make sure the offset does not drive the amplifier output beyond its $\pm 12V$ operating range.

The largest concern is the 2mV range, where the gain is equal to 1000. On this range it can be seen $25mV \times 1000 = 25V$, which is well beyond the possible range of the amplifier.

Using $+V_R$ and a pair of film resistors (R423 and R424) an effective constant current null is provided. The ratio formed by R423 and R424 $\times 2V_R$ provides the voltage. This voltage is constant with respect to the gate of Q413A because of the bootstrap. R417 provides the current and is selected to provide $\pm 25mV$ offset correction range.

4-21. NMRR Filter and Buffer

Additional NMRR is provided in the preamp using a three-pole cascaded filter. As can be seen from Figure 4-7, the three poles are provided by three RC networks.

By effectively switching the filters in and out the following sequence of events occur.

When FET Q419 turns on, so does Q405, Q407 and Q409. The filters are now in the circuit and the input signal is now filtered and amplified. The filter settling time is equal to 200 milliseconds. After the 200 millisecond interval the signal integration is done by the A/D. FET Q420 now turns on, and FETs Q419, Q405, Q407 and Q408 turn off. Since no filter is in while the amplifier looks at "zero," settling time depends on amplifier speed and is 4 milliseconds. The zero is then integrated by the A/D.

The reason the filter must shut off is so the A/D can record amplifier zero right after it records signal. By keeping the time delay between signal and zero as small as possible, effective noise and drift are reduced to the desired level. Concurrently, filtering of normal mode signals is accomplished only when needed; when looking at the signal.

The first pole is formed by R416, C407 and Q409. The on resistance of Q409 maintains closed loop gain at all frequencies greater than 10 which maintains amplifier stability. The second pole is formed by C406, R406 and Q407. It is buffered from the third pole by U401B. The third pole is formed by R401, C403 and Q405. All three poles have the same time constant of 10 milliseconds. U401A buffers the output of the third pole.

Buffers U401A and U401B are bootstrapped in a similar fashion to the input amplifier. VR401 and VR402 provide the $\pm 6.2V$ reference, and emitter followers Q401 and Q402 supply the current to U401, R407C and R407D bias the references. The effect of this bootstrap is to provide higher CMRR to U401, therefore improving linearity.

The bootstrap circuit adds a pole to the frequency response of U401B. The dominant pole formed by R407A, R407B, C401 and C402 maintains stability of the bootstrap circuit. Q403 and Q404 are low capacitance FETs used as diode clamps to the bootstrap circuit to prevent latch up resulting from driving inputs to U401B out of their common mode range during overload.

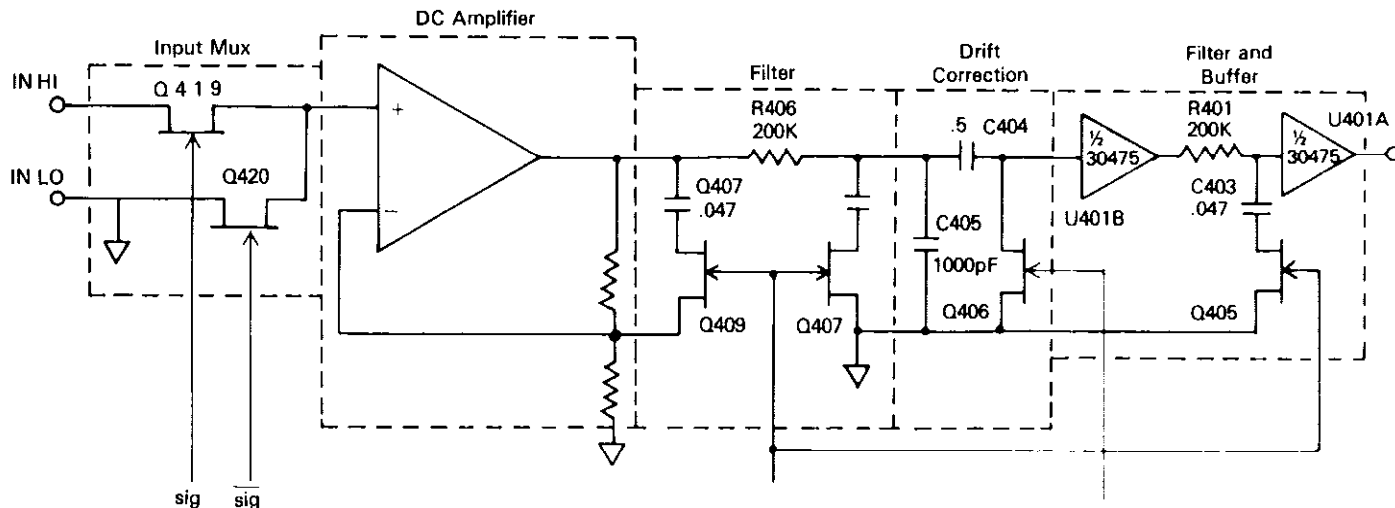

FIGURE 4-7. NVPA Showing Filter and Drift Correction

4-22 Drift Correction

The offset resistors R423 and R424 bring the amplifier into the operating range. The offset can only be nulled to 2mV referred to the input. At the output on X1000, 2V can be present. The A/D would be overloaded by $\pm 2.4V$ which means the 2V component must be offset to 0V for 0V_{in}.

This offset correction is provided by C404, Q406 and low leakage buffer U401B. When Q420 is on and when the A/D is not looking at preamp zero (during the A/D zero cycle) Q406 turns on and stores the offset voltage present on the DC amplifier output on C404. Then this capacitor holds this value during the next two conversions (.5 sec) until it is updated. This correction occurs two times a second. Leakage off this capacitor will yield offsets on the 200 millivolt range with input shorted. The major source of leakage is U401B and Q406. These two devices are selected for leakage to maintain less than 15 microvolts of drift over a conversion cycle of 50 millisecond. This is the time it takes to do a full preamp signal/zero conversion. C405 prevents preamp slewing (between signal and zero FET switching) from affecting the charge on C404.

4-23 Input Protection

CR402 and CR403 prevent input stage foldover which would severely drop input impedance during overload. This also prevents long recovery time caused by unbalancing power dissipation between Q413A and Q413B. Q410 and Q411 prevent the amplifier from getting lost during a range change or severe overload by clamping the summing junction at $\pm 1V$. CR404, CR405, R427 and R428 provide a ground referenced $\pm 0.7V$ threshold for the protection circuitry. High impedance ($> 10^9$ ohm) is not affected by the protection circuit for input voltages less than 1 volt because of low leakage FET pair Q415 and Q416. However, for inputs greater than 1 volt, the input voltage is clamped and current limit is provided through R436.

4-24 Input Mux Pumpout

Input Mux spikes caused by gate to channel capacitance of the input mux FETs (Q419 and Q420) are attenuated by applying an approximately equal but opposite polarity spike. C416, R403, R404, R412, and Q408 provide this spike cancellation. C417 acts to filter the high frequency components of the pumpout. R412 allows adjustment to less than 2 millivolts p-p across C417 with a 10 meg shunt across the input

4-25 FET Multiplexing

Input and filter FET multiplexing is accomplished using the open collector comparators U402 and U403. A reference for the comparators is provided by R407J and R407K along with the +5V supply. The N-channel FETs employed throughout the circuitry require a -5V to -10V V_{GS} to shut them off and -2V to -1V to saturate them (turn them on). In all cases the gate drive is the same. Turn off is provided by driving the gate to -15V. Turn on is provided by driving the gate to the channel potential (drain/source voltage). Bootstrapping is provided where needed to bring gate voltage up to channel voltage.

4-26 Input Mux

Special consideration is given to input multiplexing of Q419 and Q420, which needs to be thermally stable in order to maintain low drift. Low thermal drift is accomplished primarily through the use of PC board layout techniques and copper leaded FETs. An isothermal surface is created by placing the two FETs (Q419 and Q420) extremely close to each other. The pads to which Q419 and Q420 are soldered are heat sunked together with thermal compound, which is held in place with a specially molded retainer cup. Any temperature gradients affecting one FET affects the other FET equally and they cancel. Low thermal connection is made to these FETs through thin copper PC tapes. The tapes must be thin so they can support thermal gradients. The source of Q419 terminates at a large, bare copper pad to which protection resistor R436 (with bare

copper lugs) is bolted. The opposite end of R436 is bolted to a bare copper lug to which the input cable is fastened. The HI and LO input lines are bare copper, cold welded joints. The sensitive input circuitry is covered (both sides of the board) with a relatively airtight compartment to eliminate thermal gradients caused by air current flow and to act as an electrostatic shield.

4-27 A/D Converter

While studying the A/D converter theory of operation, it will be helpful to refer to the Schematic Diagram 30585D (Analog Board PC-529).

The 181 analog board (PC 529) contains the A/D converter and high voltage signal conditioning circuitry. Q301, Q302, VR301, R301, R302 and R317 make up the input protection for the A/D. C301 provides improved NMRR above 80Hz and protects K301 from V-Hz signals. On the 2V range, the signal is applied directly to the A/D through Q304. R313 is the input attenuator which acts as a precision 10 to 1, 100 to 1, and 1000 to divider depending on range. Refer to Table 4.3.

**TABLE 4-3
GAIN RESISTORS FOR VOLTS**

Range	Ratio	Adjustment
20V	10 to 1	R315
200V	100 to 1	R309
1KV	1000 to 1	R310

Adjustment R314 trims the total resistance of R313 and is set to center position unless R309, R310 or R315 ends up out of range during calibration. When this happens, adjusting R314 brings the adjustment back in range.

4-28 Timing

When reading this section on timing, reference to Figures 4-8 and 4-9 will be helpful.

On the mV ranges, the sequence starts with S9 going high. This action turns on the signal mux FET Q419 and turns off Q420. A 200msec delay time is allowed because of the preamp NMRR filter. After 200msec, signal integration is performed by the microprocessor-controlled A/D converter. A few milliseconds must elapse after integration is finished before Q419 can turn off and Q420 turn on. Once this zero FET is turned on (Q420), only 4msec wait is necessary because the filter has also been switched off. The zero integration is then performed by the A/D.

A few milliseconds after preamp zero is completed, either S3 or S4 is turned on. If after the previous preamp cycle S3 is turned on, S4 will turn on this time and vice versa. After 4msec amplifier delay time (allowing U301 to settle), either an A/D zero or an A/D cal integration will be performed. Once all four integrations have been obtained, the updated reading can be calculated from:

$$\text{Reading} = \frac{V_{\text{sig}} - V_{\text{zero}}}{V_{\text{ref}} - V_{\text{A/D zero}}}$$

Each integration is performed over a one-line cycle: 16.66msec for 60Hz; 20.0msec for 50Hz. A total of four readings per second are obtained in this manner.

Considering the V ranges the sequence is exactly the same except that Q306 is off. Instead, the appropriate signal FET is turned on depending on range. Refer to Table 4.4.

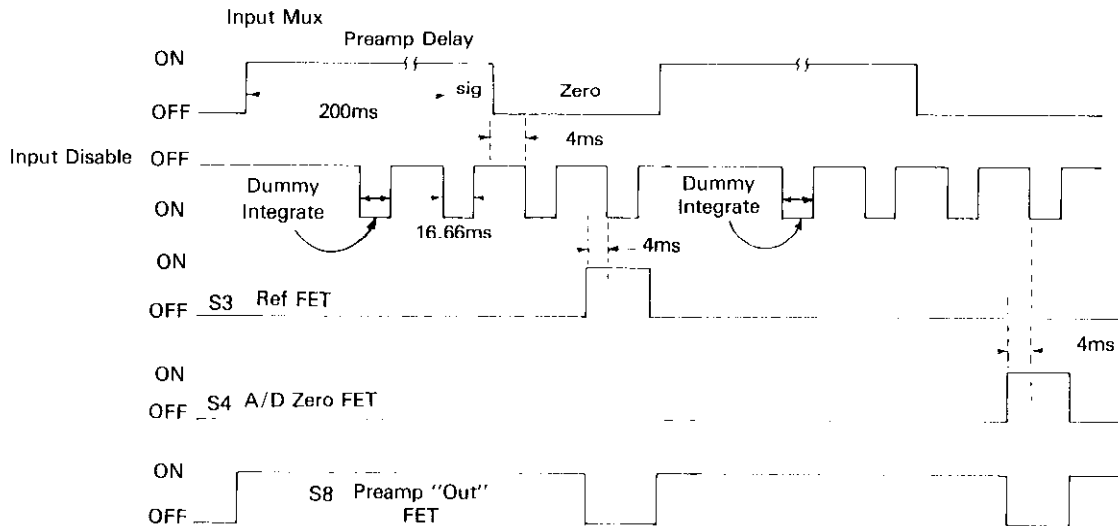

FIGURE 4-8. Preamp A/D Timing

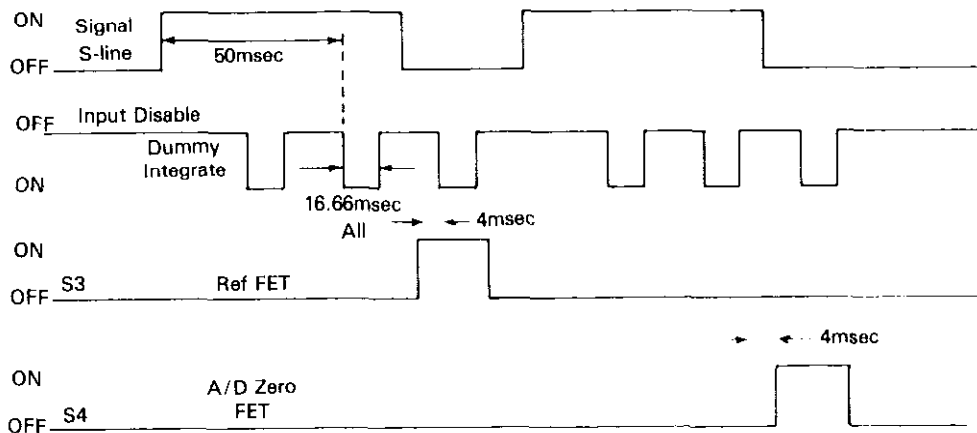

FIGURE 4-9. V range A/D Timing

TABLE 4-4
MUX FETs

Range	S Line Mux	FET	Relay
mV	S8	Q306	K301 ON (Not Muxed)
2V	S7	Q304	K301 ON (Not Muxed)
20V	S7	Q304	K302 ON (Not Muxed)
200V	S6	Q305	
1000V	S5	Q307	

Note that the FETs are muxed between phases of measurements.

4-29. Mux FETs

The Mux drive to the gates is the same as for the Mux FETs of the Preamp. Q304-Q309 are low leakage devices which require high gate resistance to prevent demodulation of high frequency noise which results in tens of microvolts of offsets. R333, R335, R342 and R343 are provided for this reason. U307 and U308 are open collector comparators that are used to drive the FETs. The reference for the comparators are provided by R324J and R324K.

U301 and its associated components provide a bootstrapped, unity gain input buffer. Q313 provides high current output capability.

Figure 4-10 is a block diagram of the A/D converter.

4-30. Transconductance Amplifier (GAMP)

This amplifier performs two functions:

- A. The GAMP provides an offset current so that the bipolar input voltage supplied to it is converted to a unipolar output current.
- B. The GAMP converts the input voltage to a current which goes to the integrator when requested.

Figure 4-11 shows how the circuit operates. The transconductance amplifier provides excellent current linearity.

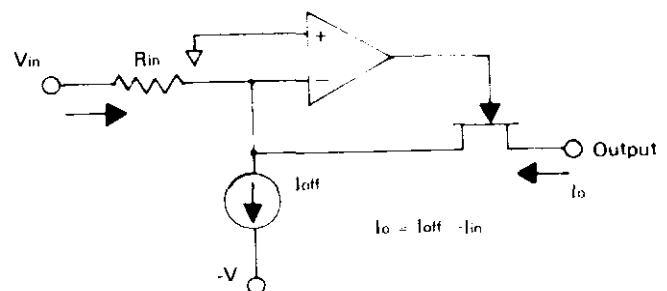

FIGURE 4-11. Transconductance Amplifier

$$I_{off} \text{ is made } \approx \frac{V_{in}}{R_{in}}$$

Thus when $V_{in} = V_{in \text{ max}}$, $I_o \approx 0$ (pos. full scale)

$$V_{in} = 0, I_{in} = I_{off} \text{ (zero)}$$

$$V_{in} = -V_{in \text{ max}}, I_o = I_{off} + \frac{V_{in}}{R_{in}} \approx 2 I_{off} \text{ (minus full scale)}$$

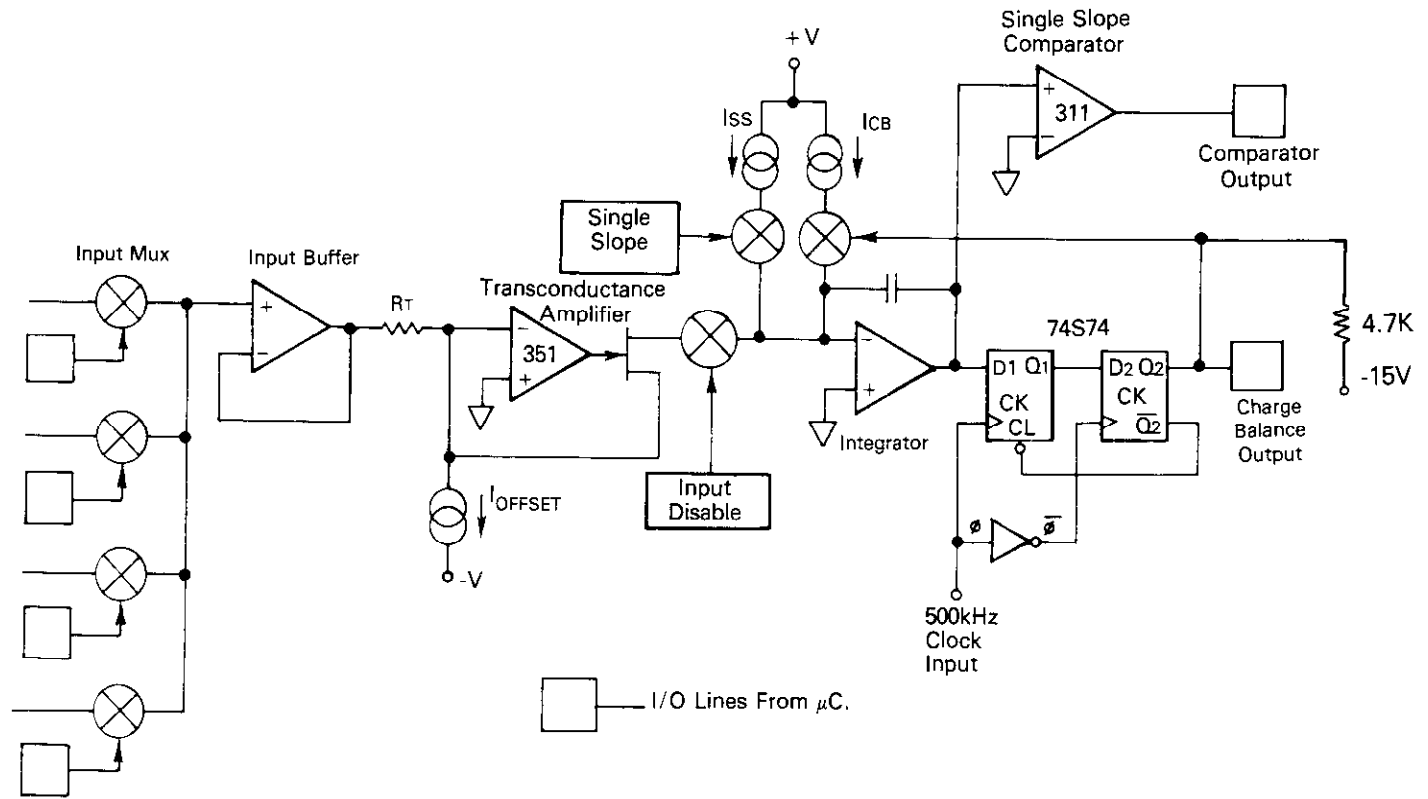

FIGURE 4-10. Simplified A/D Diagram

4-31. Integrator

The integrator has been designed to guard against the most common problems associated with high speed integrator operation. Active integrators have two major problems which limit their high speed performance: the crossover distortion and the gain bandwidth of the integrator amplifier. These effects can be seen by looking at the integrator model in Figure 4-12. When a voltage step appears at V_{in} , the amplifier will not respond immediately and C will initially be a short circuit. Then:

$$e \sim e_o = V_{in} \frac{R_o}{R_o + R_{in}}$$

as shown in the equation, the effect is that the wrong current will be applied to the capacitor until the amplifier recovers. It can also be seen that if a bipolar input amplifier was used for the integrator, charge could be conducted away from the capacitor and cause significant errors. To guard against these problems, the 181 uses a bias resistor on the integrator output to $-15V$ to keep R_o small into the MHz region, and all inputs to the integrator are current sources. A FET input op amp is used which allows a few volts to appear on the summing junction with no loss in charge.

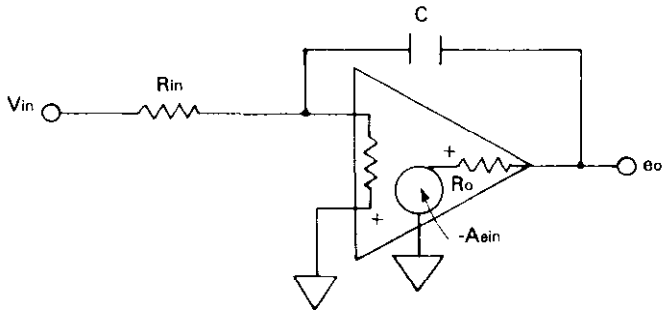

FIGURE 4-12. Integrator

4-32 Reference Supply

The reference supply is shown in Figure 4-13. The A/D was designed for low noise and linearity. This means that accuracy and stability must be provided by the reference supply. The heart of the reference supply circuit is a buried layer zener diode with an on board heater. The zener is used because of its stability, low noise, low dynamic resistance and low temperature coefficient qualities. It is driven by a constant current developed by U305. Since the zener is well regulated, it is immune to power supply variations.

Super stable tracking resistors are used in the reference divider to provide a very stable 2 volt reference.

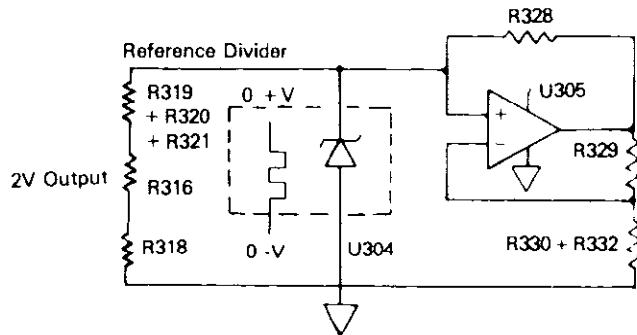

FIGURE 4-13. Reference Supply

Section 5. Maintenance

5-1. GENERAL

This section contains information necessary to maintain the Model 181. Adjustment/Calibration, troubleshooting and fuse replacement procedures are provided. Calibration should be performed yearly (every 12 months) or whenever 24 hour specifications are desired or whenever performance verification (see Section 3) indicates that the Model 181 is out of specifications. If any step in the calibration procedure cannot be performed properly, refer to the troubleshooting information in this section or contact your Keithley representative, or the factory.

NOTE

Because of special handling, expertise, and equipment that is required, it is strongly recommended that the 181 be sent back to the factory for service and/or calibration.

WARNING

All service information is intended for qualified electronic maintenance personnel only.

5-2. Recommended Test Equipment

Recommended test equipment for calibration is listed in Table 5-1. Alternate test equipment may be used. However, the accuracy of the alternate test equipment must be at least three times better than the Model 181 specifications, or equal to Table 5-1 specifications.

5-3. Voltage Divider

The Voltage Divider (B) recommended is not readily available on the commercial market. The following information is provided in order that this divider may be constructed.

**TABLE 5-2
VOLTAGE DIVIDER PARTS LIST**

Keithley Part Number	Description
BP-11-0	Black Binding Post
BP-11-1	Red Binding Post
Model 1485 N/A	Low-Thermal Female Input Connector 100k Ω , .01%, 10ppm/ $^{\circ}$ C, Wirewound Low Thermal Construction
N/A	100 Ω , .01%, 10ppm/ $^{\circ}$ C, Wirewound Low Thermal Construction
Model 1483	Low Thermal Construction Kit

Refer to Figure 5-1 for recommended construction of the Voltage Divider. The connections on the Model 1485 (Low Thermal Female Connector) should be clean before being crimped. The connections on the binding posts should be clean and soldered with Cadmium solder. The crimp connectors and the Cadmium solder are provided in the Model 1483 Low Thermal Connection Kit. Insulating foam is to be wrapped around the resistors to impede air currents which could cause thermal EMFs. The connection from the 181 to the divider is made by a low thermal cable terminated by two 1486s (Male Low Thermal Connectors). This cable will also have to be constructed. Refer to Figure 5-2 and 5-3.

The following materials are required for construction of special cables:

- A. Model 1482 Low-Thermal Input Cable
- B. Model 1486 Male Low-Thermal Connector
- C. 2 WA-29 Washer
- D. 1 19166 Strain relief

**TABLE 5-1
RECOMMENDED TEST EQUIPMENT**

Item	Description	Specifications	Mfr.	Model
A	DC Calibrator	1.9V, 19V, 190V, 1000V \pm .001% (10ppm)	Fluke	332D
B	Voltage Divider	\pm .01% (10ppm)		
C	Oscilloscope	2mC/cm	Tektronix	7603
D	DMM	.003% + 1d	Racal-Dana	5900
E	Maintenance Kit		Keithley	1815
F	Kelvin Varley Divider			720A
G	Low Thermal Input Cable		Keithley	1481
H	Low Noise Preamplifier		Ithaco	1201

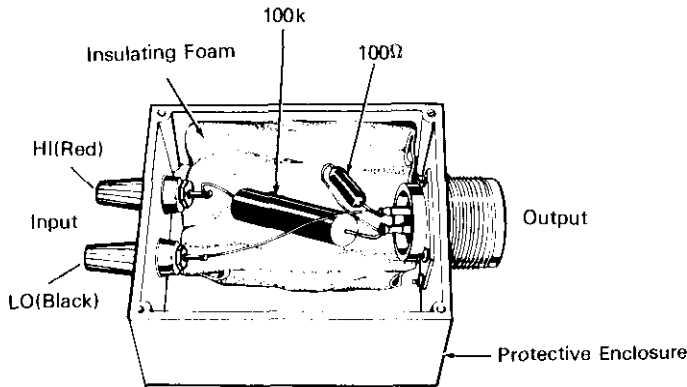
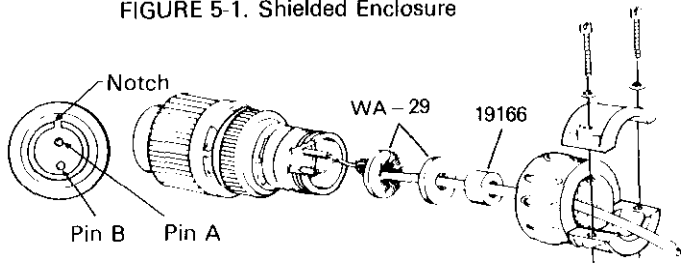

FIGURE 5-1. Shielded Enclosure



Pin "A" crimps to the center conductor of the triax cable. Pin "B" crimps to the inner copper shield of the triax cable. The case connects to the outer shield of the triax cable.

FIGURE 5-2. Connector Assembly

To prepare a low noise triaxial cable for either direct connections to a source or for connector assembly the steps outlined below should be followed.

- A. Gently cut through the outer insulation without cutting the outer shield.
- B. Using a sharp point, unravel the braided shield.
- C. Twist the braid (outer shield) and thoroughly clean off traces of graphite.
- D. Gently cut through the inner insulation without cutting the inner shield.
- E. Using a sharp point, unravel the braided shield.
- F. Twist the braid (inner shield) and thoroughly clean off all traces of graphite.
- G. Cut the center conductor to the proper length and strip the insulation off of the center conductor.
- H. Refer to Figure 5-2 and crimp the center conductor to Pin A. Crimp the inner shield to Pin B. Place the outer shield braid between the two washers and secure the back of the connector as shown.

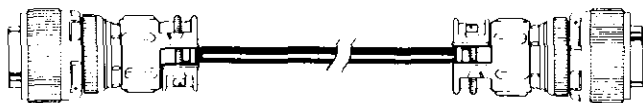

FIGURE 5-3. Male to Male Connector

Refer to Figure 5-4 for a complete picture of the Calibrator to Voltage Divider to 181 Connection.

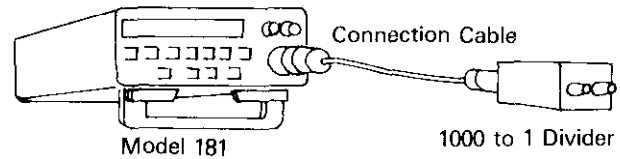

FIGURE 5-4. Divider Connection

5-4. Environmental Conditions

Calibration of the Model 181 should be performed under laboratory conditions having an ambient temperature of 23°C +1°C and a relative humidity of less than 60%.

NOTE

Calibration should be performed by qualified personnel using accurate and reliable equipment.

5-5. CALIBRATION PROCEDURE

Perform the following procedures and make the adjustments indicated to calibrate the Model 181.

WARNING

Some procedures require the use of high voltage. Take care to prevent contact with live circuits which could cause electrical shock resulting in injury or death

CAUTION

Do not exceed maximum allowable input voltage. Instrument damage may occur. Maximum allowable input is stated in the specifications.

5-6. Installation of the Calibration Cover (30915C)

The Calibration Cover is included in the Model 181 maintenance kit. The calibration should be performed using the calibration cover. The cover permits access to the Model 181 adjustments while allowing the instrument to reach normal internal operating temperature. Install the cover as follows:

1. Remove the two rear panel screws that secure the top cover in place.
2. Remove the top cover by lifting firmly upward.
3. Install the cal cover in place of the top cover. Install the two screws that secured the top cover in Step 1.
4. The instrument should stabilize for 4 hours at the specified environmental conditions.

5-7. A/D Calibration (2V Range) 1

1. Depress the power button. This turns the unit ON. With the cal cover installed allow four hours warmup time. The four hour warmup time allows the 181 to achieve optimum drift performance.
2. Connect LO lead of the DC calibrator to earth ground. Connect the output of the calibrator (A) to the banana jack inputs (Voltage Ranges) on the 181. (No input leads are to be connected to mV input.)
3. Dial the DC calibrator to ZERO. Select the 2V range. Press the Zero button. Check the Front Panel to see that the Zero

LED is lit. Dial an output of +1.90000V on the calibrator. Adjust R316 on the Analog Board until the display reads 1.90000V +1 digit. Take note of the reading.

4. Press the ZERO button on the 181 twice to rezero the instrument. Reverse the polarity of the input. Dial an output of 1.90000V on the calibrator (A). Make sure the 181 reads the same as in Step 3 ±3 digits. If the reversal error is out of specification, then Model 181s with Potentiometer R344 can be adjusted as in Step 5. For 181s without R344 and out of reversal error specification, refer to the troubleshooting section.

5. Adjust R344 until the reading is the same as in Step 3 ±3 digits.

5-8. 10Meg Adjustment [2]

Adjust R314 for the center of its span. When a problem is encountered (adjustment runs to the limit of its span) during adjustment of step 3, 4 or 5, use R314 to bring the adjustment on range. Then go back and recalibrate the 20V, 200V, and 1000V ranges.

5-9. 20V Range Adjustment [3]

Repeat Step 3 of A/D Calibration but use the 20V range, input 19.0000V and adjust R315 to obtain a reading of 19.0000V ±1 digit. If the reversal in Step 5 (Paragraph 5-7) is greater than +3 digits, refer to the troubleshooting section.

5-10. 200V Range Adjustment [4]

Repeat Step 3 of A/D Calibration but use the 200V range, input 190.000V and adjust R309 to obtain a reading of 190.000V ±1 digit. If the reversal in Step 5 (paragraph 5-7) is greater than ±3 digits, refer to the troubleshooting section.

5-11. 1000V Range Adjustment [5]

Repeat Step 3 of A/D Calibration but use the 1000V range, input 1000.00V and adjust R310 to obtain a reading of 1000.00 ±1 digit. If the reversal in Step 5 (paragraph 5-7) is greater than ±2 digits, refer to the troubleshooting section.

5-12. D/A Calibration [6] [7]

1. Select X1, on the analog output switch located on the rear panel. Connect the Model to analog output.
2. Select the 2V range and input 2.10000V. Verify that the 181 display reads OFLO.
3. Adjust R106 for an output voltage of -2.000V ±.05% (±1mV) read on the display.
4. Input +2.10000V into the 181 and verify that the 181 display reads OFLO.
5. Adjust R107 for an output voltage of +2.000V ±.05% (±1mV) read on the display.

5-13. Nanovolt Preamp Calibration [8]

(Cannot be done until 2V range is calibrated).

1. Pumpout
 - A. Connect a 10MΩ probe to the 181 Preamp Input (mV input). Connect the other end of the probe to the input of the Ithaco Low Noise Preamp. Connect the output of the Preamp to the oscilloscope. A low thermal connection is not necessary here.

B. Adjust R412 until AC pumpout (1 1000Hz B W F) is less than 2mV p-p.

2. Gain

The test fixture (1000 to 1 divider) for gain adjustment must have low thermal connections to the nanovolt preamp. A precision 1000 to 1 divider is recommended so that a standard DC calibrator can be used (1V_{in} = 1mV out)

3. 2 Millivolt Range [9]

A. Measure the resistors in the divider separately using the 5900 (on 90 day spec). Take note of each resistance and use the following formula to get an exact ratio:

$$\frac{\text{Lesser Resistance}}{\text{Lesser Resistance} + \text{Greater Resistance}} = \text{Ratio}$$

For Example:

$$\begin{aligned} \text{Lesser Resistance} &= 99\Omega \\ \text{Greater Resistance} &= 100.02k\Omega \\ \frac{99}{99 + 100.02K} &= .0009888 = \text{Ratio} \end{aligned}$$

B. Connect the DC calibrator, 1000 to 1 divider and the 181 as shown in Figure 5-5. Allow approximately one minute for thermal EMFs to settle out. Turn HI RES on.

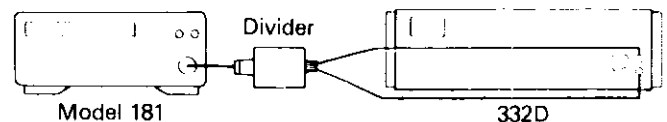

FIGURE 5-5. Preamp Calibration

- C. Select the 2mV range. Dial the DC calibrator to 0.000000 and press the ZERO on the front panel of the 181.
- D. Apply 1.90000V to the divider box. Allow the 181 to settle. Now take the ratio just calculated and multiply it by Full Scale which will be applied by the calibrator. For example

$$\begin{aligned} .0009888 \times 1.90000V &= 1.87872mV \\ (\text{Ratio}) \quad (\text{Applied}) &= (\text{Expected}) \\ \text{Input} &= \text{Reading} \end{aligned}$$

This is the reading to expect on the 181 when 1.900000V is applied from the calibrator into the divider and the divider resistances turn out to be as the example shows. Adjust R409 to obtain the calculated reading ±25 digits. Be sure to allow sufficient settling time for the instrument.

- E. Dial the output of the calibrator to an output of 0.000000. Allow the instrument to settle. Check to see if zero has changed. The input connector thermal EMFs may or may not have settled so Zero may not be the same. If zero has changed, rezero and repeat Step D until the result is repeatable.

20 Millivolt Range 10

A. Select the 20mV range and rezero the 181.

B. Repeat Step 3D except for a calibrator output of 19.00000V and adjust R410 for the reading calculated ± 10 digits.

5. 200 Millivolt Range 11

A. Select the 200mV range.

B. Connect the DC calibrator, Kelvin-Varley Voltage divider and 181 as shown in Figure 5-6.

C. Dial the DC calibrator to 0000000 and press the zero button on the front panel.

D. Dial the Kelvin-Varley Voltage Divider to 0100000 and the DC calibrator to 1.900000V. Adjust R411 for a displayed reading of 190.0000 ± 10 digits.

This completes the full calibration of the 181. If calibration cannot be accomplished proceed to troubleshooting information in this section.

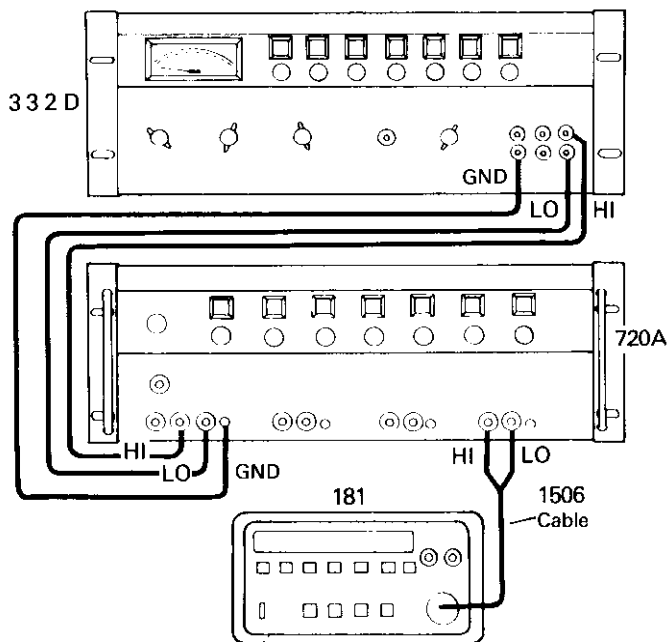

FIGURE 5-6. DC Calibrator, Kelvin-Varley Divider and 181

5-14. TROUBLESHOOTING

The troubleshooting instructions contained in this section are intended for qualified personnel having a basic understanding of analog and digital electronic principles and components used in a precision electronic test instrument. Instructions have been written to assist in isolating the defective circuit or subcircuit. Isolation of the specific defective component has been left to the troubleshooter.

NOTE

For instruments that are still under warranty (less than 12 months since date of shipment), if the instrument's performance is outside of specifications at any point, contact your Keithley representative or the factory before attempting troubleshooting or repair other than fuse replacement.

5-15. Special Handling of Static Sensitive Devices

CMOS and NMOS devices are designed to function at very high impedance levels for low power consumption. For this reason normal static charge build up on your person or clothing can be sufficient to destroy these devices. Step 1 lists the static sensitive devices in your Model 181. The remaining steps provide instruction on how to avoid damaging them when they must be removed/replaced.

1. Static sensitive devices:

Keithley Part No.	Reference Designation
IC-250	U104
IC-251	U120, U121
IC-247	U117
PRO-106-00 (2716)	U102
PRO-107-00 (2716)	U103
LSI-6	U108
LSI-18	U109
LSI-28	U110
LSI-14	U131
IC-229	U133
IC-229	U134

2. The above integrated circuits should be handled and transported only in protective containers. Typically they will be received in metal tubes or static protective foam. Keep the devices in their original containers until ready for use.
3. Remove the devices from their protective containers only at a properly grounded work bench or table, and only after grounding yourself by using a wrist strap.
4. Handle the devices only by the body. Do not touch the pins.
5. Any printed circuit board into which a device is to be inserted must also be grounded to the bench or table.
6. Use only grounded tip soldering irons.
7. Use only anti-static type solder suckers.
8. After soldering the device into the board, or properly inserting it into the mating receptacle, the device is adequately protected and normal handling can be resumed.

5-16. Line Power

In general, start troubleshooting with the Line Power Checks and Main Supplies listed in Table 5-3. These checks will verify that the power supplies are providing the correct voltages to the electronic components.

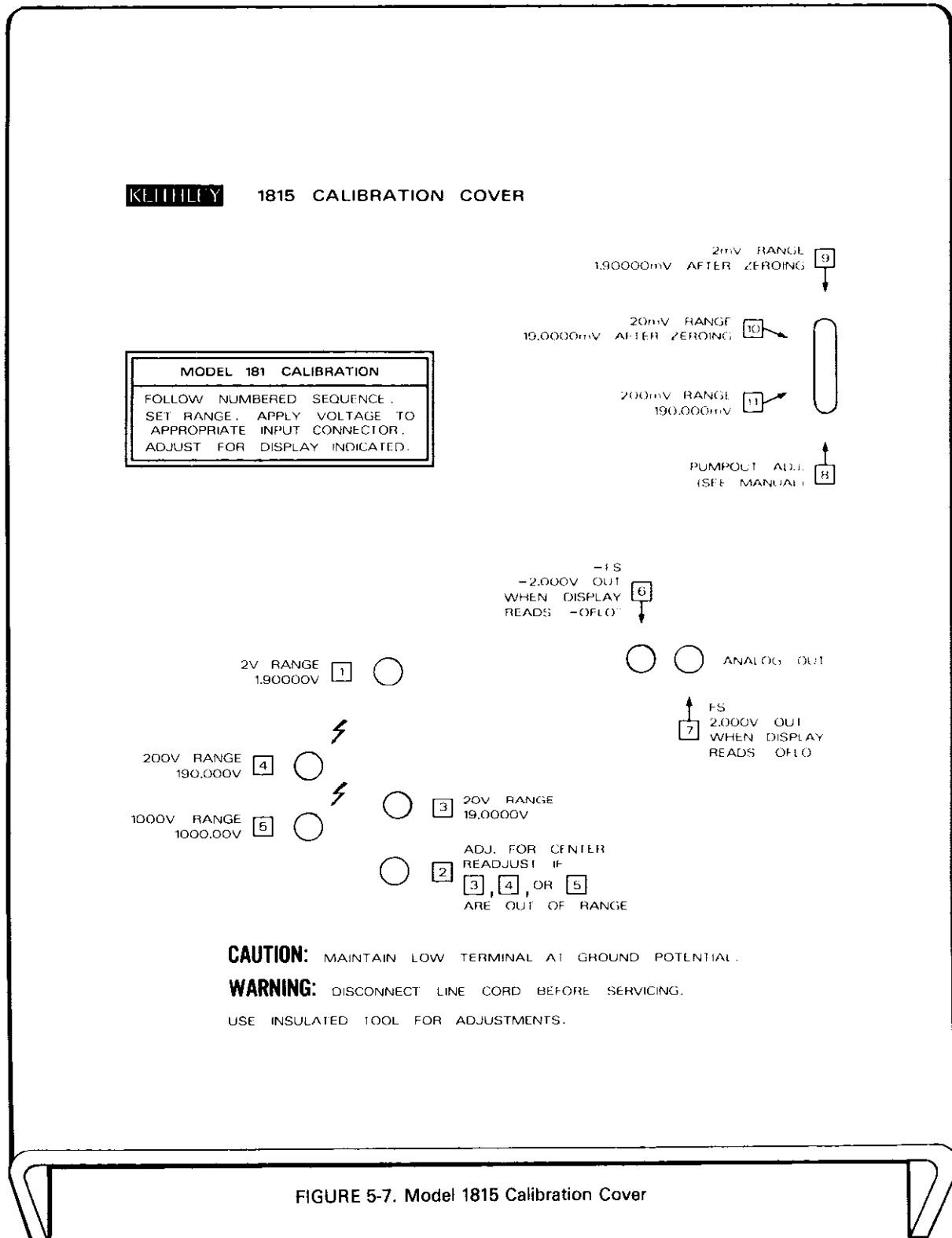

FIGURE 5-7. Model 1815 Calibration Cover

This is what the top of the calibration cover looks like. Follow the procedure and locate the adjustment as shown above:

TABLE 5-3
POWER SUPPLY CHECKS

Step	Item/Component	Required Conditions	Remarks
1	S102 Line Switch	Must be set to 115V or 230V as appropriate	
2	F101 Line Fuse	Continuity	
3	J1101 Line Cord	Plugged into live receptacle. Turn on power	
4	Output of U128	+5VDC, +5%	+5V Analog Supply*
5	Input of U128	+7.6V Minimum	Input of +5V Regulator
6	Output of U129	+15V, ±5%	+15V Analog Supply*
7	Input of U129	+17.9V Minimum	Input of +15V Regulator
8	Output of U130	-15V, ±5%	-15V Analog Supply*
9	Input of U130	-17.9V Minimum	Input of -15V Regulator
10	Output of U137	-15V, ±5%	-15V Digital Supply**
11	Input of U137	-17.9V Minimum	Input of -15V Regulator
12	Output of U136	+15V, ±5%	+15V Digital Supply**
13	Input of U136	+17.9V Minimum	Input of +15V Regulator
14	Cathode of CR101 or Collector of Q105	+5V, ±5%	+5V Digital Supply**
15	Input of U135	+14.25V Minimum	Input of +5V Regulator
16	Emitter of Q105	+6.7V Minimum	Input to Output Regulation Transistor

* Referenced to Input LO

** Referenced to Analog Output LO

5-17. A/D Converter and Display

Proper operation of the A/D converter and the display should be verified before troubleshooting the nanovolt preamp and signal conditioning circuits. Certain basic checks are listed in Tables 5-4 and 5-5. These checks should be made to ascertain that the A/D converter circuit is functioning properly. The cir-

cuit diagram of the A/D converter is located on two Schematics, 30585D and 30583D Sheet 2 of 2. Reading the Theory of Operation for the A/D converter is strongly recommended before troubleshooting the A/D. There are several waveforms provided to help isolate the problem.

TABLE 5-4
A/D CONVERTER

Step	Item/Component	Required Conditions	Remarks
1		Turn on Power and select 20mV range. Short the mV inputs and V.	All voltage and waveform measurements are referenced to input LO unless otherwise noted.
2	Display	0.0000 \pm 5 digits 0.0000 Hi Res Engaged	
3	Check main power supplies	Refer to Table 5 - 2	
4	U301	+5.6V	Bootstrap Supply*
5	U301 Pin 4	-5.6V	Bootstrap Supply*
6	U305 Pin 6	10V \pm 10%	Output of Reference Supply
7	Source of Q309	2V Cal	2V if Calibrated, measure with a high impedance voltmeter ($> 10^9\Omega$).
8	Anode of VR302	-6.4V, \pm 5%	
9	U127C Pin 8	TTL level square wave at 3.84MHz Rate	3.84MHz Clock
10	U123A Pin 5 U309A Pin 3	TTL level square wave at 480kHz rate Refer to Figure 5 - 8	480kHz Clock
11	U105 Pin 1 U110	TTL level pulses at 2.4kHz rate Refer to Figure 5-9	2.4kHz Clock
12	U307 Pin 14 R324 Pin 5	-15V	Gate Drive of Q309
13	Emitter Q313	*See Waveform of Figure 5 - 18	A/D Buffer Output with 10mV applied
14	U302 Pin 2	* -2.49V, \pm 7% (± 175 mV)	Transconductance Amp (GAMP) bias
15	U306 Pin 6 R327 Pin 7	*See Waveform of Figure 5 - 17	Integrator Output Waveform
16	U127B Pin 5, U122A Pin 6 Q320C Pin 6, U309B Pin 5	*TTL level pulses Refer to Figure 5 - 10	Input Disable
17	U126 Pin 13, P1010 Pin 3 U309 Pin 10	*TTL level pulses Refer to Figure 5 - 16	V - F pulses to Counter
18	U303 Pin 2	*5V, \pm 7% (350mV)	Charge Dispenser Bias
19	U110 Pin 16, AT101 Pin 4	*TTL level pulses Refer to Figure 5 - 12	Charge Balance/Single Slope Waveform at At101
20	AT102 Pin 4, U126 Pin 2 U120 Pin 1, U121 Pin 1	*TTL level pulses Refer to Figure 5 - 13	Reference to Analog Out LO Strobe pulses of AT102
21	AT103 Pin 4, U120 Pin 2	**TTL level pulses Refer to Figure 5 - 14	Data to U120
22	AT104 Pin 4, U120 Pin 3 U121 Pin 3	*TTL level pulses Refer to Figure 5 - 15	Clock pulses for shift registers U120 and U121

*Referenced to the emitter of Q313.

Figure 5-18 is the A/D Buffer Output Waveform. The 181 is on the 20mV range with 10mV applied to the input. This waveform begins with a 200msec delay and then a signal integrate takes place. After the signal integrate, the preamp zero takes place. Then a 2V cal is performed. When the 2V cal is complete, another 200msec delay occurs. The 200msec delays are to allow sufficient time for the preamp to settle. After the delay and another preamp zero, an A/D zero takes place. Notice the two zeroes are different in value. Another 200msec delay occurs and the whole phase starts over again.

5-18. Display Board

The Display Board circuitry has two drive circuits that operate the display. The segment drive circuitry (Q201 thru Q208) is connected to all displays in parallel. The digit drive circuitry enables all segments of a single digit one at a time. All signals are referenced to digital common. Check these circuits per Table 5-5.

5-19. Nanovolt Preamp Noise Troubleshooting

Begin the troubleshooting procedure by checking the 2V range. If this range is noisy, the A/D or digital circuitry are most likely at fault. If the 2V range is quiet, the nanovolt preamp is most likely at fault. Components suspected of generating noise should be checked. That is, the noise level of the device should be measured and verified as out of spec before replacing the device.

For examining the noise level of the devices utilize the Ithaco Model 1201 Low Noise Preamplifier (Item H of Table 5-1). Set the gain to 1000 and the bandwidth to 1-30Hz. An X1 shielded probe is recommended for use. The output of the Model 1201 preamplifier should be plugged into an oscilloscope. The oscilloscope can then be set to the desired sensitivity (e.g. 10V on scope = 10mV referred to the input). It is not uncommon to have 60Hz pickup superimposed on the noise waveform. The 60Hz can be ignored as long as it is low (less than 20µV p p referred to the input).

5-20. Preamp Noise Troubleshooting Checks

The Nanovolt Preamp operation is explained in the Theory of Operation. It is recommended that the troubleshooter read the Nanovolt Preamp section of the Theory of Operation before troubleshooting the Preamp. Table 5-6 is a step by step procedure to breakdown and isolate the problem.

5-21. Checks of Preamp Zero

- A. Select 2mV range. Short the mV input with a low thermal shunt.
- B. Monitor U404 Pin 7 for a reading of less than ±2V. If Pin 6 is within ±2V, proceed to Step 2. If Pin 7 is greater than ±2V reselect R423 and R424 per the following procedure.

**TABLE 5-5
DISPLAY**

Step	Item/Component	Required Condition	Remarks
1		Turn on Power Select 20mV DC range Short input	All voltages referenced to Analog Output Low
2	U203, Pin 14	5 Volts + 5%	If Low Check Per Table 5-2
3	U203, Pin 8	TTL level Square Wave at 1.2kHz Rate	Clock for Display
4	U203, Pin 1	TTL level digital pulses	
5	U203, Pin 3, 4, 5, 6, 10, 11, 12, 13	Digit and Annunciator Drive High - Enable	
6	U201, Pin 1, 13, 9, 7 U202, Pin 1, 13, 9, 7	Digit and Annunciator Drive Output Low - Enabled	Digit Drivers
7	Q201-208	5 Volts on Emitter	Segment Drivers
8	DS202-207 Pin 1, 2, 4, 6, 7, 9, 10	Segment Drive High - Enabled	Output of segment drivers. Collectors of Q202-Q208
9	J1008, Pin 13	TTL level Digital Pulses	Press S201, S207, S208
10	J1008, Pin 12	TTL level Digital Pulses	Press S202, S206, S209
11	J1008, Pin 11	TTL level Digital Pulses	Press S203, S205, S210
12	J1008, Pin 10	TTL level Digital Pulses	Press S204, S211

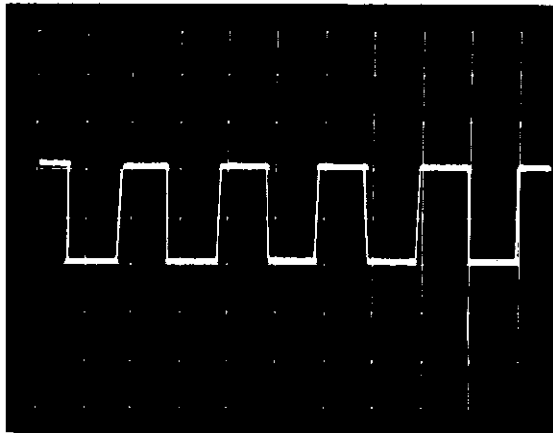

FIGURE 5-8. 480kHz Clock 1 μ sec/cm 2V/cm
(U309A Pin 3)

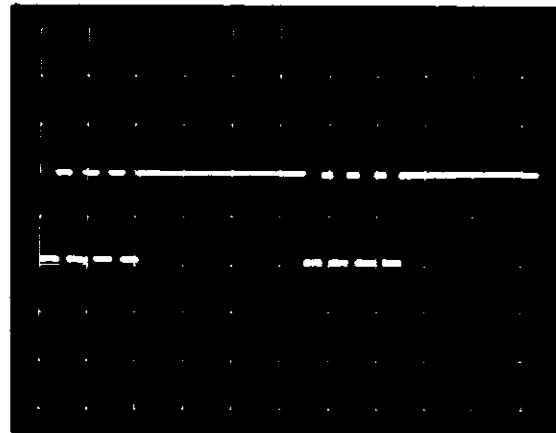

FIGURE 5-11. Input Disable 50msec/cm 2V/cm
(J1010 Pin 2)

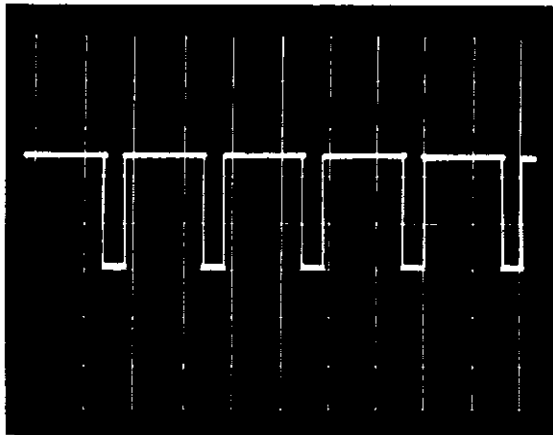

FIGURE 5-9. 2.4kHz Clock .2 μ sec/cm 2V/cm
(U105 Pin 1)

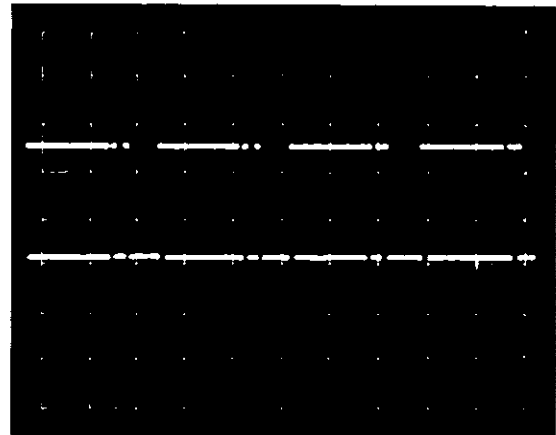

FIGURE 5-12. AT101 Output 10msec/cm 2V/cm
(AT101 Pin 4)

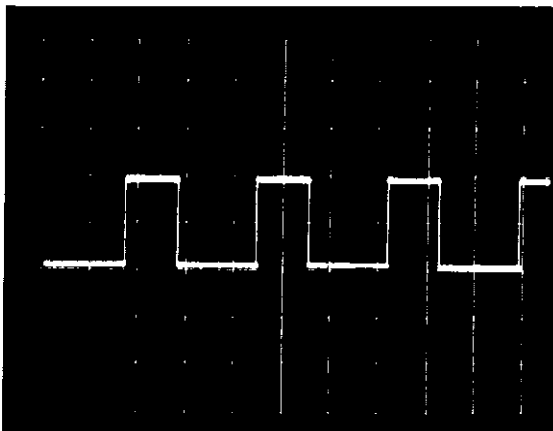

FIGURE 5-10. Input Disable 10msec/cm 2V/cm
(U127B Pin 5)

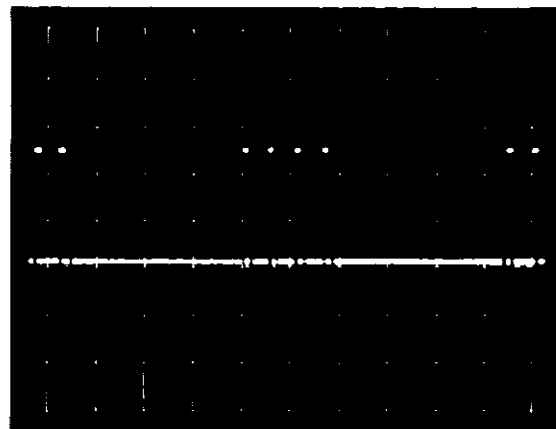

FIGURE 5-13. Strobe Pulses 10msec/cm 2V/cm
(AT102 Output Pin 4)

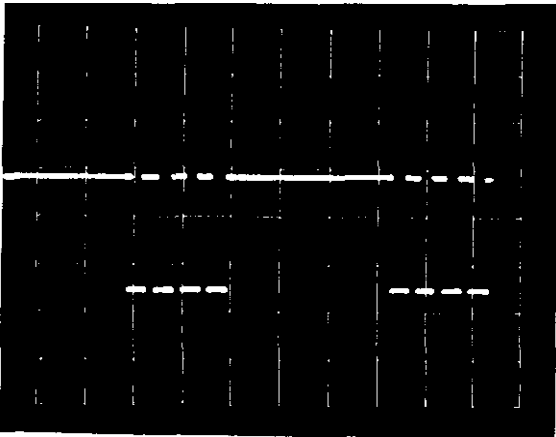

FIGURE 5-14. AT103 Output 10msec/cm 2V/cm
(AT103 Pin 4)

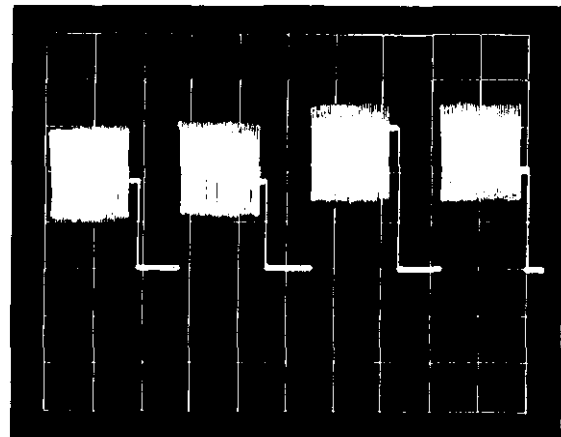

FIGURE 5-17. Integrator Output 10msec/cm .5V/cm
(U306 Pin 6)

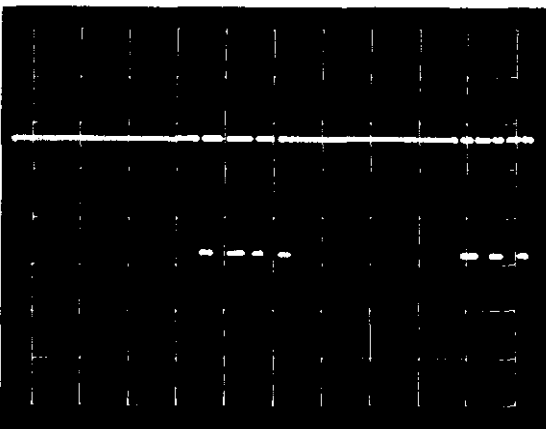

FIGURE 5-15. AT104 Output 50msec/cm 2V/cm
(AT104 Pin 4)

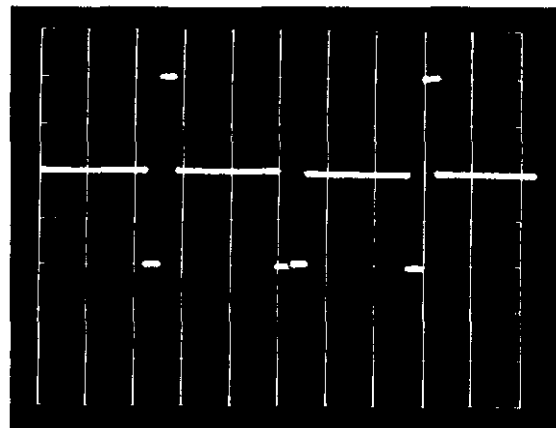

FIGURE 5-18. A/D Output Buffer Output 100msec/cm 5V/cm
(emitter of Q313)

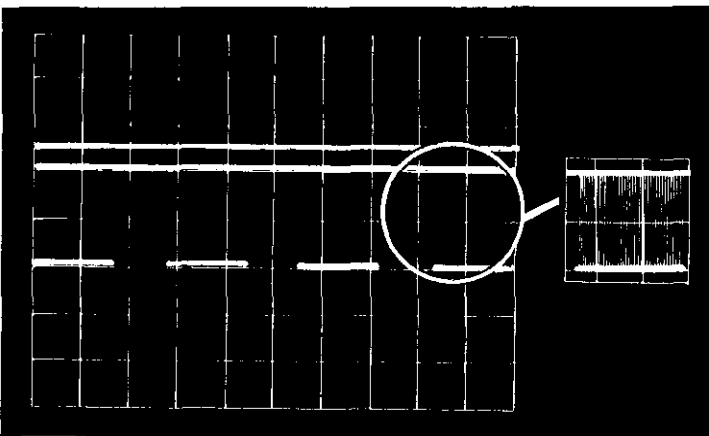

FIGURE 5-16. V-F Output 10msec/cm 2V/cm
(U126 Pin 13)

C. Setting Offset Null

1. Remove R423 and R424.
2. Place a 20K Ω potentiometer across the three Berg pins on the preamp board. Connect the wiper of the pot to the center Berg pin (pin B). Connect the other pins of the pot to the other two Berg pins (pins A,B).
3. Select the 2mV range and short the input.
4. Adjust the 20K Ω potentiometer until the U404 Pin 6 is less than 0.5V. Measure the resistance of the potentiometer from the wiper to both ends.
5. Replace R423 and R424 with the nearest value 1% film resistors as measured on the potentiometer.

5-22. Buffer Check

- A. Select the 200mV range. Short the input.
- B. Monitor U401 Pin 1 and verify the noise level as less than 20 μ V p-p. If the noise level is greater than 20 μ V p-p, replace U401. Refer to Figures 5-19 and 5-20 for noise level. The output of U401 is sensitive to probe capacitance. Isolate with a 1K resistor. If U401 is quiet, proceed to Paragraph 5-23.

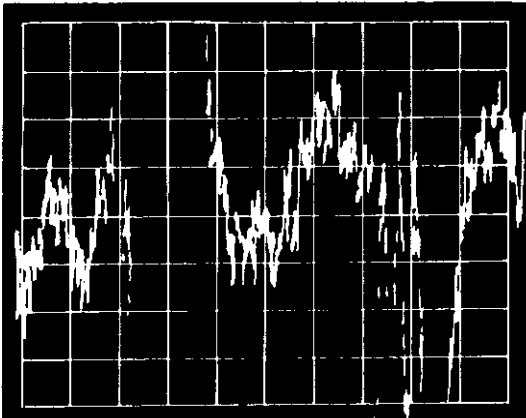
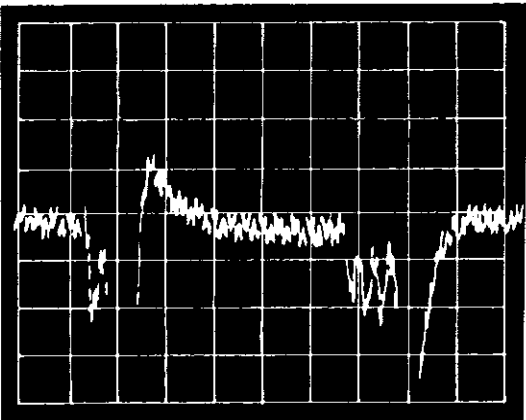
FIGURE 5-19. Noisy Q413 10 μ V/cm 50ms/cmFIGURE 5-20. Quiet Q413 10 μ V/cm 50ms/cm**5-23. Input Current Check**

Perform the following checks at less than 80% relative humidity.

- A. Select the 20mV range. Install a shielded 1M Ω resistor across the input. Select the following functions: Damping In, Filter In, Hi Res off.
- B. Check the display for less than 500 digits. If the reading is out of spec, note whether it is positive or negative
- C. If the display is negative, and greater than 500 digits, lift the gate lead of Q416 from the PC board and then check the display for less than 500 digits. If the display is still out of spec, replace Q419 and Q420 and resolder the gate of Q416.
- D. If the display is positive and greater than 500 digits, lift the gate lead of Q415. Check the display for less than 500 digits and if it is in spec after the gate lead has been lifted off the PC board, replace Q415. Otherwise, Q413 is at fault

5-24. Bootstrap Check

Monitor U404 Pin 3 for less than 10 μ V p-p noise. Monitor U404 Pin 1 for less than 10 μ V p-p noise. If Pin 1 has a greater amount of noise than Pin 3, replace U404

5-25. Low Noise Supply Check

- A. Select the 20mV range. Monitor the noise level on U405 Pin 5. Verify that it is less than 10 μ V p-p. If Pin 5 noise level is greater than 10 μ V p-p, the possible causes are components VR404 and CR406.
- B. If U405 Pin 5 noise level is less than 10 μ V p-p, verify that U405 Pin 3 noise level is less than 10 μ V p-p. If U405 Pin 3 noise level is greater than 10 μ V p-p, the possible causes are VR403 or CR407.
- C. If U405 Pin 3 noise level is less than 10 μ V p-p, verify that U405 Pins 7 and 1 noise level is less than 10 μ V p-p. If U405 pins 7 and 1 noise level is greater than 10 μ V p-p, replace U405. After U405 is replaced, verify that Pins 7 and 1 are 10 μ V p-p.
- D. \pm VR have been verified as having less than 10 μ V p-p noise. If this is not the case, examine the associated components C412, C413, R421, R422 and R413 for poor solder joints or defects. Do not advance to the next step unless \pm VR noise level is less than 10 μ V p-p.

5-26. Current Bias Check

Monitor the noise level on the emitter of Q414 for less than 20 μ V p-p. If Q414 emitter has a noise level greater than 20 μ V p-p, replace Q414. If replacing Q414 did not solve the noise problem, examine R431 thru R433 for poor solder joints or defects. Refer to Figures 5-21 and 5-22

5-27. Input FET Replacement

- A. If the 181 is still noisy after all the previous checks have been made, the problem is apparently the input FET Q413A and B.
- B. Replace Q413A and B with Keithley Part No. 30809 which is a matched set. Reselect R423 and R424 as stated in Paragraph 5-21. Verify noise and drift performance.

5-28. Nanovolt Preamp Troubleshooting

The Nanovolt Preamp operation is explained in the Theory of Operation. It is recommended that the troubleshooter read the Nanovolt Preamp section of the Theory of Operation before troubleshooting the Preamp. The following Table 5-6 is a step by step procedure to breakdown and isolate the problem quickly and easily.

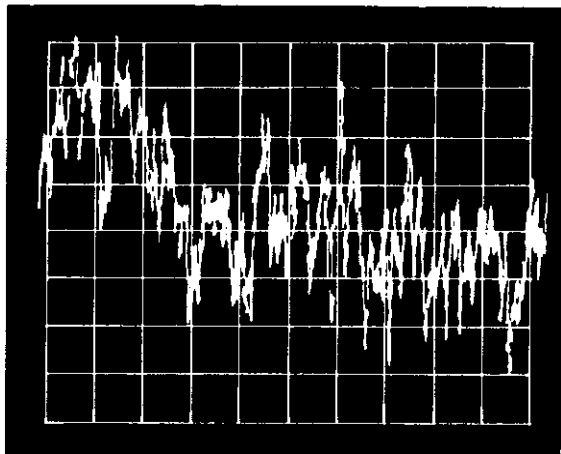

FIGURE 5-21. Noisy U401 10 μ V/cm 50ms/cm

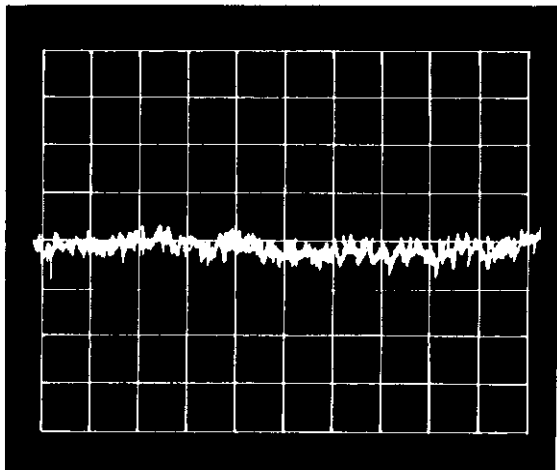

FIGURE 5-22. Quiet U401 10 μ V/cm 50ms/cm

5-29. DC Volts Attenuator Troubleshooting

The DC Volts Attenuator is made up of a precision voltage divider (R313A, B, C and D, R314, R315, R309, R310 and R311), ranging relays (K301 and K302) and input protection FETs (Q301 and Q302). The Attenuator is located on the Analog Board PC-529. The Attenuator divides the input signal to the appropriate switching FET.

5-30. IEEE Bus Circuit Troubleshooting

Bus address toggle switches (S103) set the Bus address. The address cannot be changed while power is applied. To change this address, select new address by S103 and cycle the power.

1. Visually check the 181 display to see that it is operating properly. If it is nonfunctional, flickering or displaying incorrect data then check the display circuit U110, U201, U202, U203, Q201-Q208. If the display is operating properly, then proceed to Step 2.
2. Program the controller to input any command string and output data. Check buffers U133 and U134 for input and output of data. Check T/R1 (Pin 27) and T/R2 (Pin 28) of U131 for toggling I0 to 5V switching).
3. Check to see that the Bus Address can be changed. Turn off the instrument and toggle in a different Bus Address. Turn power on and see that the new Bus Address is present by appropriate controller address.

5-31. D/A Circuit Troubleshooting

1. Visually check the 181 display to see if it is operating properly. If it is nonfunctional, flickering or displaying incorrect data then check the display circuit U110, U201, U202, U203, Q201-Q208. If the display is operating properly, then proceed to Step 2.
2. Input a ramp voltage of -2V to +2V at a .5Hz rate to the Banana Jacks on the 2V range. Using an oscilloscope measure the signals located on Pins 4-15 of U117. The signals should be switching from 0 volts to +5 volts (toggling). This should be done with the Analog Output Gain Switch to X1. If the pins are toggling proceed to the analog section of the D/A circuit. If the pins are not toggling proceed to Step 3.
3. Monitor bits 1-4 of U117 to see that they are toggling. If they are not toggling, check U110. If the pins are toggling, then proceed to Step 4.
4. Monitor bits 5-12 of U117 to see that they are toggling. If they are not toggling and Pin 11 (Enable of U116) is toggling, then U116 is bad. If Pin 11 (Enable of 116) is not toggling, then check U110. If Pin 5-12 of U117 are toggling, then the digital section of the D/A circuit is functioning properly.

5-32. Switch Input Section Troubleshooting

The switch input section is shown on Schematic 30583D, Sheet 2 of 2 and consists of U104, Q102, R101, R129, and R133.

Check that the Front Panel Range and Function Switches operate properly. Also check that the appropriate frequency was displayed upon power up. If the Front Panel Switches operate properly and the appropriate frequency was displayed upon power up, then the Switch Input Section is operating properly. If the Front Panel Switches are not operating properly or an inappropriate reading for frequency was displayed upon power up, then check U104, Q102, R101, R129 and R133.

TABLE 5-6
PREAMP TROUBLESHOOTING

Step	Item/Component	Required Conditions	Remarks
1	Test point A (+VR)	+ 10V \pm 10%	+ Bootstrap supply for Input FETs
2	Berg Pin C	- 10V \pm 10%	- Bootstrap supply for Input FETs
3	U402 Pin 13	0 to - 15V pulses	Gate drive for Q419
4	U402 Pin 14	0 to 15V pulses	Gate drive for Q420
5	U403 Pin 13	0 to 15V pulses, corresponds to Step 3 pulses	Turns on Filter and Buffer while Q419 is on
6	Drain of Q413A Q412 Pin 6 (base)	5.5V \pm 5%	Input to HI Gain Amplifier
7	Drain of Q413B Q412 Pin (base)	5.5V \pm 5%	Input to HI Gain Amplifier
8	Q412 Pin 7	10V \pm 5%	Input to U404
9	U404 Pin 1	0V \pm 50mv	Bootstrap Common
10	U401B Pin 5	*0 to 1V pulses	Input of U401B which is the Buffer between the 2nd and 3rd pole of the Filter
11	U401V Pins 6 and 7	*0 to 1V pulses	Output of U401B
12	U401A Pin 8	+ 5.6V \pm 10%	+ Bootstrap Supply to U401A
13	U401A Pin 4	- 5.6V \pm 10%	Bootstrap Supply U401A
14	U401A Pin 3	*0 to 1V pulses	Input to U401A (Isolate probe capacitance with a 1K resistor)
15	U401A Pins 1 and 2	*0 to 1V	Output of Nanovolt Preamp

* 10mV applied to the mV input terminal with 20mV range selected

NOTE: All voltages referred to Input LO with Input shortened and 20mV range selected

TABLE 5-7
DCV ATTENUATOR TROUBLESHOOTING

Step	Item/Component	Required Conditions	Remarks
1		Select 2V range Apply 1V.	
2	K301 Pin 7	Read 1V input signal	K301 is engaged
3	Source of Q304	Read 1V input signal	
4		Select 20V range Apply 10V to input	
5	K302 Pin 7 Source of Q304	Read 1V	
6		Select 200V range Apply 100V to input Read 1V	
7		Select 1000V range	
9	R310 wiper	Read 1V	

5-33. Digital Troubleshooting

1. Monitor the clock on the $\phi 2$ Line (Pin 37 or U109) for a 1MHz square wave.
2. Monitor the clock on Pins 38 and 39 of U109 for a 4MHz square wave.
3. Check the Reset line (Pin 40 of U109). It should be logic HI. Display will be blank if the Reset line is a logic LO.
4. Check CA2 (Pin 39 of U110) for clear pulses at a 1.2kHz rate. Check CS2 (Pin 23 of U110) for U110 to be accessed with a low true signal.
5. If CS2 is not accessed with a low true signal, then check the address lines A11, A12, A14 and A15 on U101 to see that they are switching between 0V and +5V. If the address lines are switching, then check U101.
6. Check the VMA line (Pin 5 of U109, Pin 1 of U101) to see that it is switching between 0V and +5V.

7. Check IRQ line for a logic low every 833μ seconds (1.2kHz rate).

NOTE

If the previous troubleshooting checks reveal no problem, then the unit must be returned to the factory for repair. This is due to the complexity of the troubleshooting equipment required.

5-34. Q413 Installation

Use Figure 5-23 to install the matched J-FET pair (Keithley P/N 30809) in PC-526.

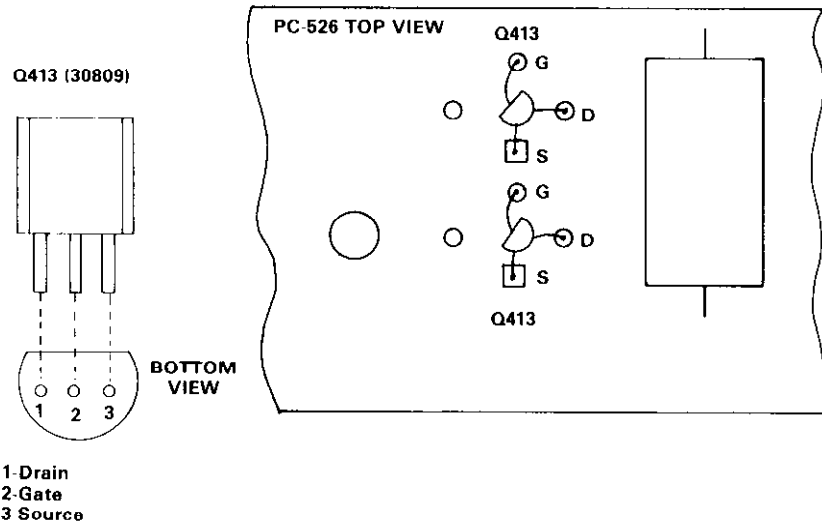

Figure 5-23. Q413 Installation

Section 6. Replaceable Parts

6-1. GENERAL

This section contains information for ordering replacement parts. The Replaceable Parts List is arranged in alphabetical order of the circuit designations of the components. A cross-reference list of manufacturers containing their addresses is given in Table 6-1.

6-2. Ordering Information

To place an order or to obtain information concerning replacement parts contact your Keithley representative or the factory. See the inside front cover for addresses. When ordering, include the following information:

- A. Instrument Model Number
- B. Instrument Serial Number
- C. Part Description
- D. Circuit Designation (if applicable)
- E. Keithley Part Number

6-3. Factory Service

If the instrument is to be returned to the factory for service, please complete the Service Form which follows this section and return it with the instrument.

6-4. Component Layouts

The component layouts are as follows:

- A. Nanovolt Preamp Board, PC-526, Dwg. No. 30377D, Figure 6-1.
- B. Analog Board, PC-529, Dwg. No. 30503D, Figure 6-2.
- C. Display Board, PC-530, Dwg. No. 30537D, Figure 6-3.
- D. Digital Board (mother board), PC-531, Dwg. No. 30576D, Figure 6-4.

6-5. Schematics

The Model 181 has four schematic diagrams, and they are as follows:

- A. Nanovolt Preamp Board, PC-526, Schematic No. 30586D, Figure 6-5.
- B. Analog Board, PC-529, Schematic No. 30585D, Figure 6-6.
- C. Display Board, PC-530, Schematic No. 30584D, Figure 6-7.
- D. Digital Board, PC-531, Schematic No. 30583D, Figure 6-8.

TABLE 6-1
Replaceable Parts List
PC-531 - Schematic 30583D

Circuit Desig.	Description	Schematic Location	PC-Board Item No./Location	Mfr. Code	Mfr. Desig.	Keithley Part No.
AT-101	Opto Isolator	E2	195/D2	MOT	MOC5005	IC-292
AT-102	Opto Isolator	E3	196/D2	MOT	MOC5005	IC-292
AT-103	Opto Isolator	E4	197/D3	MOT	MOC5005	IC-292
AT-104	Opto Isolator	E4	198/D3	MOT	MOC5005	IC-292
AT-105	Opto Isolator	F6	199/D3	MOT	MOC5005	IC-292
C-101	.1 μ F, 16V, CerD	B5 ¹	4/A3	CLB	UK16-104	C-238-.1
C-102	.1 μ F, 16V, CerD	D5 ¹	5/A2	CLB	UK16-104	C-238-.1
C-103	.1 μ F, 16V, CerD	E6 ¹	6/B2	CLB	UK16-104	C-238-.1
C-104	.1 μ F, 16V, CerD	A5 ¹	7/C2	CLB	UK16-104	C-238-.1
C-105	.0068 μ F, 500V, CerD	E5 ¹	3/C2	SPG	5HGAD68	C-22-.0068
C-106	22pF, 1000V, CerD	B4 ¹	9/C2	CLB	DD220	C-64-22pF
C-107	22pF, 1000V, CerD	B4 ¹	10/C2	CLB	DD220	C-64-22pF
C-108	.1 μ F, 16V, CerD	B2 ¹	11/B2	CLB	UK16-104	C-238-.1
C-109	.1 μ F, 16V, CerD	D3 ¹	12/B2	CLB	UK16-104	C-238-.1
C-110	390pF, 500V, CerD	B5	13/C4	CLB	DD391	C-22-390pF
C-111	.1 μ F, 16V, CerD	E2 ¹	14/D2	CLB	UK16-104	C-238-.1

TABLE 6-1
 Replaceable Parts List
 PC-531 - Schematic 30583D
 (Continued)

Circuit Desig.	Description	Schematic Location	PC-Board Item No./Location	Mfr. Code	Mfr. Desig.	Keithley Part No.
C-112	.1 μ F, 16V, CerD	E2 ¹	15/D2	CLB	UK16-104	C-238-.1
C-113	.1 μ F, 16V, CerD	E4 ¹	16/D3	CLB	UK16-104	C-238-.1
C-114	.1 μ F, 16V, CerD	E4 ¹	17/D3	CLB	UK16-104	C-238-.1
C-115	.1 μ F, 16V, CerD	F6 ¹	18/D3	CLB	UK16-104	C-238-.1
C-116	.1 μ F, 16V, CerD	G4 ¹	19/D2	CLB	UK16-104	C-238-.1
C-117	.1 μ F, 16V, CerD	G5 ¹	20/E2	CLB	UK16-104	C-238-.1
C-118	.1 μ F, 16V, CerD	F3 ¹	21/E3	CLB	UK16-104	C-238-.1
C-119	68pF, 1000V, CerD	F4 ¹	22/D3	CLB	DD-680	C-64-68pF
C-120	47pF, 1000V, CerD	F5 ¹	23/D3	ERI	Type 838	C-64-47pF
C-121	.1 μ F, 16V, CerD	F4 ¹	24/D4	CLB	UK16-104	C-238-.1
C-122	.1 μ F, 16V, CerD	F5 ¹	25/E3	CLB	UK16-104	C-238-.1
C-123	6.8 μ F, 25V, Electro	D2	26/E2	NIC	25UKB6R8DM	C-314-6.8
C-124	1500 μ F, 25V, Electro	C2	27/F2	NIC	25ULA1500	C-314-1500
C-125	1500 μ F, 25V, Electro	C1	28/E2	NIC	25ULA1500	C-314-1500
C-126	1500 μ F, 25V, Electro	C1	29/F2	NIC	25ULA1500	C-314-1500
C-127	6.8 μ F, 25V, Electro	D1	30/E3	NIC	25UKB6R8DM	C-314-6.8
C-128	6.8 μ F, 25V, Electro	D2	31/F3	NIC	25UKB6R8DM	C-314-6.8
C-129	2200pF, 500V, CerD	--	32/F4	ERI	TYPE831	C-22-2200pF
C-130	10,000 μ F, 10V, Electro	C4	33/F3	NIC	10UP10,000	C-304-10,000
C-131	.02 μ F, 500V, CerD	B4	34/G2	ERI	TYPE811	C-22-.02
C-132	6.8 μ F, 25V, Electro	D3	35/F4	NIC	25UKB6R8D17	C-314-6.8
C-133	6.8 μ F, 25V, Electro	D3	36/F4	NIC	25UKB6R8D17	C-314-6.8
C-134	100 μ F, 35V, Electro	C3	37/F4	NIC	35ULA100	C-295-100
C-135	100 μ F, 35V, Electro	C3	38/G4	NIC	35ULA100	C-295-100
C-136	.1 μ F, 16V, CerD	G2	40/F4	CLB	UK16-104	C-238-.1
C-137	1 μ F, 50V, Polycarb	D5	41/C4	ECI	625BIA105	C-215-1
C-138	1 μ F, 20V, Tant	C1 ¹	42/B2	SIE	821A105K020N	C-204-1
C-139	470pF, 2000V, CerD	D3	45/D3	ACI	470pF	C-324-470pF
C-140	680pF, 2000V, CerD	D3	46/D3	ACI	680pF	C-324-680pF
CR-101	Diode	D4	E4	F-I	1N4607	RF-41
CR-104	Rectifier Bridge	B4	53/F4	G-I	2735	RF-48

TABLE 6-1
 Replaceable Parts List
 PC-531 - Schematic 30583D
 (Continued)

Circuit Desig.	Description	Schematic Location	PC-Board Item No./Location	Mfr. Code	Mfr. Desig.	Keithley Part No.
CR-105	Rectifier Bridge	B1	54/E3	G-I	W04M	RF-46
CR-106	Rectifier Bridge	B2	55/F2	G-I	W04M	RF-46
CR-107	Rectifier Bridge	B3	56/F2	G-I	W04M	RF-46
F-101	Fuse 1/4A (115V)	A3	--	L-F	313, 250	FU-17
F-101	Fuse 1/8A (230V)	A3	--	L-F	--	FU-20
J1001	Binding Post (Red)	A1	--	HHS	1517	BP-11-0
J1002	Binding Post (Black)	A2	--	HHS	1517	BP-11-2
J1003	Millivolt Input Connector	A2	--	AMP	MS3102A-16-115-639	CS-387
J1004	Binding Post (Red)	D5	--	HHS	1517	BP-11-2
J1005	Binding Post (Black)	D5	--	HHS	1517	BP-11-0
J1006	IEEE Connector	H1-H4	G4	AMP	552791-1	CS-377
J1011	Power Connector	A4	--	SW1	EAC-301	CXS-254
J1012	Connector	A3	--	MOL	09-50-3031	CS-287-3
L-101	100µH Choke	F4	60/D3	NYT	SWD-100	CH-14
P1007	12 Pin Connector	H1-H5 ¹	64/D5	MOL	09-70-	CS-338-12
P1008	Ribbon Cable Assembly	D1-F1,E5 ¹	62/B4	K-I	--	30575A
P1009	13 Pin Connector	H1-H5 ¹	66/E3	MOL	09-70-	CS-338-13
P1010	14 Pin Connector	H1-H5 ¹	65/32	MOL	09-70-	CS-338-14
P1012	3 Pin Molex Connector	A3	67/F2	MOL	09-65-1031	CS-288-3
Q101	N Channel, J FET	F5 ¹	71/E3	INT	ITE392	TG-128
Q102	NPN Silicon	D6 ¹	72/D5	MOT	2N3904	TG-47
Q103	NPN Silicon	D4	73/F4	MOT	2N3904	TG-47
Q104	NPN Silicon	D4	74/F4	MOT	2N3904	TG-47
Q105	PNP Darlington	D3	75/E3	G-E	D45E1	32469-1
Q106	NPN silicon	C6	77/E5	F-I	2N3565	TG-39
Q107	NPN silicon	C6	78/E5	F-I	2N3565	TG-39
R-101		D5, D6	80/B3	--	--	TF-99
R-103	3.3K, 10%, 1/4W, Comp	E6	82/B2	BRN	CR25*	R-76-3.3K
R-104	3.3K, 10%, 1/4W, Comp	B1	83/C3	BRN	CR25*	R-76-3.3K
R-105	3.3K, 10%, 1/4W, Comp	C1	84/C3	BRN	CR25*	R-76-3.3K
R-106	10K Cermet Trimmer	C6	85/C4	BEK	72PMR*	RP-97-10K

TABLE 6-1
Replaceable Parts List
PC-531 - Schematic 30583D

Circuit Desiq.	Description	Schematic Location	PC-Board Item No./Location	Mfr. Code	Mfr. Desiq.	Keithley Part No.
R-107	10K Cermet Trimmer	B6	86/C4	BEK	72PMR*	RP-97-10K
R-108	166.3K, .1%, 1/8W, MTF	B6	87/C5	DLE	MFF1/8	R-176-166.3K
R-109	108.8K, .1%, 1/8W, MTF	B6	88/C5	--	--	R-176-108.8K
R-110	4.32K, 1%, 1/8W, Fixed	C6	89/C5	DLE	MFF1/8	R-88-4.32K
R-111	392K, 1%, 1/8W, Fixed	C5	90/C5	DLE	MFF1/8	R-88-392K
R-112	108.8K, .1%, 1/8W, MTF	C6	91/C5	DLE	CMP1/10	R-176-108.8K
R-113	1M, .1%, 1/8W, MTF	C5	92/C5	DLE	MFF1/8	R-176-1M
R-114	402K, 1%, 1/8W, Fixed	D5	93/C5	DLE	MFF1/8	R-88-402K
R-115	10K, 10%, 1/4W, Comp	B2	94/C2	BRN	CR25*	R-76-10K
R-116	10K, 10%, 1/4W, Comp	D3	95/D2	BRN	CR25*	R-76-10K
R-117	150 Ω , 10%, 1/4W, Comp	E3	96/D2	BRN	CR25*	R-76-150
R-118	150 Ω , 10%, 1/4W, Comp	E4	97/D2	BRN	CR25*	R-76-150
R-119	150 Ω , 10%, 1/4W, Comp	E4	98/D3	BRN	CR25*	R-76-150
R-120	120 Ω , 10%, 1/4W, Comp	F6	99/D4	BRN	CR25*	R-76-120
R-121	120 Ω , 10%, 1/4W, Comp	F2	100/D2	BRN	CR25*	R-76-120
R-122	10K, 10%, 1/4W, Comp	G4	101/D2	BRN	CR25*	R-76-10K
R-123	10M, 10%, 1/4W, Comp	F5	102/D3	BRN	CR25*	R-76-10M
R-124	4.7K, 10%, 1/4W, Comp	F4	103/E3	BRN	CR25*	R-76-4.7K
R-125	4.7K, 10%, 1/4W, Comp	F5	103/E3	BRN	CR25*	R-76-4.7K
R-126	22 Ω , 10%, 1/4W, Comp	F4	105/E4	BRN	CR25*	R-76-22
R-127	1.5K, 10%, 1/4W, Comp	C4	106/E3	BRN	CR25*	R-76-1.5K
R-128	1K, 10%, 1/4W, Comp	D4	107/E3	BRN	CR25*	R-76-1K
R-129	10K, 10%, 1/4W, Comp	E6	108/E5	BRN	CR25*	R-76-10K
R-130	1K, 1%, 1/2W, MTLG	D5	109/E5	DLE	CMF1/4	R-94-1K
R-131	Thick Film Resistor	G-4	110/F5	BRN	431012	TF-99
R-132	1M, 10%, 1/4W, Comp	B4	111/G1	BRN	CR25*	R-76-1M
R-134	3.3K, 10%, 1/4W, Comp	E6	113/C1	BRN	CR25*	R-76-3.3K
S-101	Switch	A3	119/A1	SHA	NE-15/F	SW-466
S-102	Switch	A2	120/G2	K-1	--	SW-425
S-103	Switch	G4	121/G5	K-I	--	SW-377
U-106	Quad 2-Input Nand	SEV ¹	132/C2	MOT	74LS00	IC-163
U-107	Quad Exclusive OR	SEV ¹	136/C2	NAT	DM7486N	IC-116

TABLE 6-1
Replaceable Parts List
PC-531 - Schematic 30583D
(Continued)

Circuit Desig.	Description	Schematic Location	PC-Board Item No./Location	Mfr. Code	Mfr. Desig.	Keithley Part No.
U-108	6010 RAM	A5 ¹	133/C2	MOT	MC6810L	LSI-6
U-109	6802 Micro Processor	B2 ¹	134/C3	MOT	MC6802P	LSI-18
U-110	6522 PIA	C3 ¹	135/C3	SYN	SYP6522	LSI-28
U-116	Latch - Tristate Output	E2 ¹	141/R4	MOT	74LS374	IC-242
U-117	Multiplying DAC	B5	142/R4	A-D	A07541JN	IC-247
U-118	FET Input Op Amp	C5	143/C4	NAT	LF351AN	IC-248
U-119	FET Input Op Amp	D5, B6 ¹	144/C4	NAT	LF353N	IC-246
U-120	8 Bit Shift Register	G4 ¹	145/E2	MOT	4094	IC-251
U-121	8 Bit Shift Register	G4 ¹	146/E2	MOT	4094	IC-251
U-122	Dual "D" Flip Flop	G3 ¹	147/D2	T-I	74LS74	IC-144
U-123	Dual 4 Bit Counter	G2, G6 ¹	148/E2	MOT	SN74LS393	IC-213
U-124	Display Driver	SEV ¹	149/E2	T-I	SN75492N	IC-169
U-125	Dual 4 Bit Counter	G6 ¹	150/D3	T-I	SN74L390	IC-212
U-126	Quad 2-Input Nand Gate	SEV ¹	151/E3	MOT	74LS00	IC-163
U-127	Quad 2-Input Nand Gate	SEV ¹	152/E3	MOT	MC74LS08P	IC-215
U-128	+5V Regulator	C2	153/E2	MOT	MC7805CP	32468-1
U-129	+15V Regulator	C2	154/F3	NAT	LM341P15	32468-2
U-130	-15V Regulator	C1	155/F3	SIG	79M15CU	32468-3
U-131	IEEE Interface Chip	F2	156/E5	MOT	MC68488	LSI-14
U-132	Tri-state Buffer	F4	157/E5	F-I	74LS3679C	IC-161
U-133	Bidirectional Bus Driver	G2	158/F5	MOT	MC3447L	IC-229
U-134	Bidirectional Bus Driver	G3	159/F5	MOT	MC3447L	IC-229
U-135	5V Regulator	C4	160/F4	MOT	MC78L05ALP	IC-223
U-136	+15V Regulator	C3	161/F4	MOT	MC78L715CP	IC-170
U-137	-15V Regulator	C3	162/F4	NAT	TM320LZ15	IC-253
VR-102	6.2V Zener Diode	B5	171/C5	CMP	1N4577050	DZ-58
VR-103	5.1V Zener Diode	C6	172/E5	MOT	1N751	DZ-59
VR-104	5.1V Zener Diode	D6	173/E5	MOT	1N751	DZ-59
W-104	Jumper	B6	177/R3	--	--	J-3
Y-101	4.0MHZ Crystal	B3	183/C2	CTS	MP040	CR-10
Y-102	3.84MHZ	F5	184/D4	ROM	HC-18/11	CR-13

N¹ means Page 2 of 2 of Schematic 30583D.

*Followed by part description.

TABLE 6-2
Replaceable Parts List
PC-529 - Schematic 30585D

Circuit Desig.	Description	Schematic Location	PC-Board Item No./Location	Mfr. Code	Mfr. Desig.	Keithley Part No.
C-301	.01 μ F, 1200V, Polyprop	A1	4/B3	STD	--	C-286-.01
C-302	1 μ F, 50V, Cer	C2	5/C4	ERI	8121-050-651-104M	C-237-1
C-303	.1 μ F, 50, Cer	E3	6/C2	CLB	UK16-104	C-238-.1
C-304	.1 μ F, 50V, Cer	F3	7/C2	CLB	UK16-104	C-238-.1
C-305	1 μ F, 50V, Cer	G1	8/E4	ERI	8121-050-651-104M	C-237-1
C-306	1 μ F, 50V, Cer	D2	9/D4	ERI	8121-050-651-104M	C-237-1
C-307	.1 μ F, 50V, Cer	E1	10/D4	CLB	UK16-104	C-238-.1
C-308	3600pF, 500V, 5%, Polysty	G3	11/D3	MAL	Type SX	C-138-3600pF
C-309	1.5pF, 50V, Cer Tube	G2	12/C3	ERI	301-000-COKO-159C	C-282-1.5pF
CR-301	Silicon, 100V, 10mA	G6/D4	16/D4	T-I	1N4148	RF-28
CR-302	Silicon, 100V, 10mA	H6	17/D4	T-I	1N4148	RF-28
J-1009	Molex Connector 8 Pin	G1	22/E4	MOL	09-52-3082	CS-332-8
J-1010	Molex Connector 12 Pin	A5-A6	21/E2	MOL	09-52-3122	CS-332-12
K-301	Relay Sp DT	A1	87/B4	P-B	RL-68	RL-68
K-302	Relay Sp DT	B2	88/B4	P-B	RL-68	RL-68
Q-301	N-Channel JFET(to-92)	B2	26/C2	NAT	PF-5301	TG-139
Q-302	N-Channel JFET(to-92)	B1	27/C3	NAT	PF-5301	TG-139
Q-303	N-Channel JFET (to-92)	C3	28/B2	NAT	PF-5301	TG-139
Q-304	N-Channel JFET (to-92)	B3	29/B2	NAT	PF-5301	TG-139
Q-305	N-Channel JFET (to-92)	B4	30/B2	NAT	PF-5301	TG-139
Q-306	N-Channel JFET (to-92)	C3	31/B2	NAT	PF-5301	TG-139
Q-307	N-Channel JFET (to-92)	B4	32/B2	NAT	PF-5301	TG-139
Q-308	N-Channel JFET (to-92)	B5	33/B2	NAT	PF-5301	TG-139
Q-309	N-Channel JFET (to-92)	C2	34/B3	NAT	PF-5301	TG-139
Q-310	N-Channel JFET (to-92)	C3	35/C2	NAT	PF-5301	TG-139
Q-311	PNP Silicon (to-92)	D3	36/C2	MOT	2N3906	TG-84
Q-312	NPN Silicon (to-92)	D3	37/C2	F-I	2N3904	TG-47
Q-313	NPN Silicon (to-92)	D3	38/C3	F-I	2N3904	TG-47
Q-314	N-Channel FET (to-92)	E3	39/C3	NAT	SF51192	TG-128
Q-315	PNP Silicon (to-92)	F2	40/C3	MOT	2N3906	TG-84

TABLE 6-2
 Replaceable Parts List
 PC-529 - Schematic 30585D

Circuit Desig.	Description	Schematic Location	PC-Board Item No./Location	Mfr. Code	Mfr. Desig.	Keithley Part No.
Q-316	PNP Silicon (to-92)	F2	41/C3	MOT	2N3906	TG-84
Q-317	PNP Silicon (to-92)	G2	42/D3	MOT	2N3906	TG-84
Q-318	PNP Silicon	G2	43/D3	MOT	2N3906	TG-84
Q-319	NPN Silicon (to-92)	G3	44/D2	F-I	2N-3904	TG-47
Q-320	NPN Transistor Package	SEV	45/D3	K-I	--	29198
Q-321	NPN Transistor Package	SEV	46/D4	K-I	--	29198
R-301	200K, 1%, 8W, Fixed	A1	53/B3	CAD	MS-281	R-247-200K
R-302	47K, 10%, 1/4W, Comp	B2	54/B2	BRN	CR25*	R-76-47K
R-304	820K, 10%, 1/4W, Comp	B3	56/B3	BRN	CR25*	R-76-820K
R-307	390K, 10%, 1/4W, Comp	C3	59/C2	BRN	CR25*	R-76-390K
R-309	200 Ω , Cermet Trimmer	A3	61/B3	BEK	72PMR*	RP-97-200
R-310	20 Ω , Cermet Trimmer	A3	62/N3	BEK	72PMR*	RP-97-20
R-311	1K, .1%, 1/10W, Mtf.	A4	63/C3	ACI	VAR1/10*	R-263-1K
R-312	4.99K, .1%, 1/10W, Mtf.	E3	64/C3	ACI	VAR1/10*	R-263-4.99K
R-313	Thick Film Resistor	SEV	65/B3	CAO	--	TF-83
R-314	20K, Cermet Trimmer	A2	66/B4	BEK	72PMR*	RP-97-20K
R-315	2K, Cermet Trimmer	A2	67/B4	BEK	72PMR*	RP-97-2K
R-316	100 Ω , Cermet Trimmer	C1	68/C4	BRN	3299W*	RP-104-100
R-317	680K, 10%, 1W, Comp	B2	69/B4	A-B	TYPEGR*	R-2-680K
R-318	19.95K, .1%, 1/8W, WW	C2	70/C4	K-I	--	R-295-19.95K
R-319	Factory Selected	D1	71/C4	--	--	--
R-320	Factory Selected	D1	72/C4	--	--	--
R-321	46K, .1%, 1/8W, WW	C1	73/C4	KEL	--	R-295-46K
R-322	10K, 1%, 1/8W, MTLF.	E2	74/D3		MFF1/8*	R-88-10K
R-323	2.2M, 10%, 1/4W, Comp	F3	75/C3	BRN	CR25*	R-76-2.2M
R-324	Thick Film Resistor	SEV	76/C2	CTS	--	TF-87
R-325	33K, 10%, 1/4W, Comp	C6	77/C2	BRN	CR25*	R-76-33K
R-326	33K, 10%, 1/4W, Comp	C5	78/C2	BRN	CR25*	R-76-33K
R-327	Thick Film Resistor	SEV	79/D3	CTS	--	TF-85
R-328	2.74K, 1%, 1/8W, Mtf.	D1	80/C4	DLE	FMM, 1/8*	R-88-2.74K
R-329	6.49K, 1%, 1/8W, Mtf.	D2	81/D4	DLE	MFF, 1/8*	R-88-6.49K

TABLE 6-2
Replaceable Parts List
PC-529 - Schematic 30585D
(Continued)

Circuit Desig.	Description	Schematic Location	PC-Board Item No./Location	Mfr. Code	Mfr. Desig.	Keithley Part No.
R-330	4.64K, 1%, 1/8W, Mtf.	E2	82/D4	DLE	MFF, 1/8*	R-88-4.64K
R-331	100Ω, 10%, 1/4W, Comp	E1	83/D4	BRN	CR25*	R-76-100
R-332	910K, 10%, 1/4W, Comp	C4	116/B2	BRN	CR25*	R-76-910K
R-333	1M, 10%, 1/4W, Comp	B4	117/B2	BRN	CR25*	R-76-1M
R-334	1M, 10%, 1/4W, Comp	B4	118/B2	BRN	CR25*	R-76-1M
R-335	1M, 10%, 1/4W, Comp	B4	119/B2	BRN	CR25*	R-76-1M
R-336	2.7K, 10%, 1/4W, Comp	E5	120/C4	BRN	CR25*	R-76-2.7K
R-337	3.92K, 1%, 1/8W, Fixed	F5	121/C4	DLE	MFF 1/8	R-88-3.92K
R-338	39.2K, 1%, 1/8W, Fixed	F5	122/C4	DLE	MFF 1/8	R-88-39.2K
R-339	24.9K, 1%, 1/8W, Fixed	E4	123/C4	DLE	MFF 1/8	R-88-24.9K
R-340	2.5K, .1%, 1/8W, Mtf.	F1	124/C4	DLE	MFF 1/8	R-176-2.5K
R-341	328K, .1%, 1/8W, Mtf.	E1	125/C4	DLE	MFF 1/8	R-176-328K
R-342	1M, 10%, 1/4W, Comp	B5	126/B2	BRN	CR25	R-76-1M
R-343	1M, 10%, 1/4W, Comp	C5	127/B2	BRN	CR25	R-76-1M
R-344	100k, Cermet Trimmer	G3	128/B2	BRN	3686-FI-104	RP-97-100K
U-301	Operational Amplifier	C3	91/C3	K-I	--	30167
U-302	Operational Amplifier	E3	92/C3	K-I	--	30163A
U-303	Operational Amplifier	F1	93/C3	K-I	--	30154A
U-304	Voltage Reference	D1	94/C4	K-I	--	29996B
U-305	Operational Amplifier	D1	95/C4	K-I	--	30154A
U-306	Operational Amplifier	G3	96/D3	NAT	LF351N	IC-176
U-307	Quad Comparator	SEV	97/D2	NAT	LM339	IC-219
U-308	Quad Comparator	B5, B6	98/D2	NAT	LM339	IC-219
U-309	Quad 2-Input Nor Gate	SEV	99/D2	SIG	74LS02	IC-179
U-310	Dual "D" Flip Flop	F4, G4	100/D3	MOT	MC74574N	IC-216
U-311	Comparator	H3	101/D4	NAT	LM-311	IC-173
VR-301	5.1V, 10% Zener	B1	105/B2	MOT	1N751	D7-59
VR-302	6.4V, 5% Zener	E4	106/V3	SIE	1N4571	D7-60
VR-303	6.2V Zener	D3	107/C3	DIC	1N827A	DZ-48
VR-304	6.2V Zener	D3	108/C3	DIC	1N827A	D7-48

TABLE 6-3
 Replaceable Parts List
 PC-526 - Schematic 30586D

Circuit Desig.	Description	Keithley Part No.
C401	.1uF, 16V, CerD	C-238-.1
C402	.1uF, 16V, CerD	C-238-.1
C403	.047uF, 100V, Polyprop	C-306-.047
C404	.5uF, 50V, Polycarb	C-201-.5
C405	510pF, 500V, Polysty	C-138-510pF
C406	.047uF, 100V, Polyprop	C-306-.047
C407	.047uF, 100V, Polyprop	C-306-.047
C408	.015uF, 200V, Polycarb	C-221-.015
C409	.015uF, 200V, Polycarb	C-221-.015
C410	10uF, 20V, Tan	C-179-10
C411	10uF, 20V, Tan	C-179-10
C412	10uF, 20V, Tan	C-179-10
C413	10uF, 20V, Tan	C-179-10
C414	.1uF, 16V, Ceramic	C-238-.1
C415	.1uF, 16V, Ceramic	C-238-.1
C416	22pF, 500V, Polysty	C-138-22pF
C417	5000pF, 500V, Polysty	C-138-5000pF
CR401	Diode	RF-28
CR402	Diode	RF-28
CR403	Diode	RF-28
CR406	Diode, Current Regulator	TG-140
CR407	Diode, Current Regulator	TG-140
J1007	12 Pin Connector	CS-337-12
K401	Relay	RL-59
Q401	NPN Silicon	TG-47
Q402	PNP Silicon	TG-84
Q403	N, Channel J-FET	TG-139
Q404	N, Channel J-FET	TG-139
Q405	N, Channel FET	TG-128

TABLE 6-3
 Replaceable Parts List
 PC-526 - Schematic 30586D
 (Continued)

Circuit Desig.	Description	Keithley Part No.
Q406	N, Channel FET	TG-128
Q407	N, Channel FET	TG-128
Q408	NPN, Silicon	TG-47
Q409	N Channel J-FET	TG-139
Q412	NPN Monolithic Pair	TG-142
Q413	Matched J-FETS	TG-141
Q414	NPN Silicon	TG-143
Q415	N Channel FET	TG-128
Q416	N Channel FET	TG-128
Q417	N Channel FET	TG-128
Q418	N Channel FET	TG-128
Q419	N Channel FET	TG-128
Q420	N Channel FET	TG-128
R401	200K, 1%, 1/8W, Mtf.	R-88-200K
R402	33K, 5%, 1/4W, Comp.	R-76-33K
R403	22K, 5%, 1/4W, Comp.	R-76-22K
R404	22K, 5%, 1/4W, Comp.	R-76-22k
R405	33K, 5%, 1/4W, Comp.	R-76-33K
R406	200K, 1%, 1/8W, Mtf.	R-88-200K
R407	Thick Film	TF-87
R409	1K, 10%, Cermet Trimmer	RP-89-1K
R410	100 ohm, 10%, Cermet Trimmer	RP-89-100
R411	1K, 10%, Cermet Trimmer	RP-89-1K
R412	20K, 10%, Cermet Trimmer	RP-89-20K
R413	200K, 1%, 1/8W, MF	R-88-200K
R414	199.3K, 0.1%, 1/10W, Mtf.	R-263-199.3K
R415	21.93K, 0.1%, 1/10W, Mtf.	R-263-21.93K
R416	199.3K, 0.1%, 1/10W, Mtf.	R-263-199.3K
R417	75K, 1%, 1/8W, Mtf.	R-88-75K
R418	49.9K, 0.1%, 1/8W, Mtf.	R-176-49.9K
R419	49.9K, 0.1%, 1/8W, Mtf.	R-176-49.9K
R420	100K, 1%, 1/8W, Mtf.	R-88-100K

TABLE 6-3
 Replaceable Parts List
 PC-526 - Schematic 30586D
 (Continued)

Circuit Desig.	Description	Keithley Part No.
R421	56.2K, 1%, 1/8W, Mtf.	R-88-56.2K
R422	56.2K, 1%, 1/8W, Mtf.	R-88-56.2K
R423	*, 1%, 1/8W, Mtf.	R-88-*
R424	*, 1%, 1/8W, Mtf.	R-88-*
R427	100K, 5%, 1/4W, Comp	R-76-100K
R428	100K, 5%, 1/4W, Comp.	R-76-100K
R429	2K, 0.1%, 1/10W, WW	R-291-2K
R430	2K, 0.1%, 1.10W, WW	R-291-2K
R431	15K, 1%, 1/8, Mtf.	R-88-15K
R432	4.99K, 1%, 1/8W, Mtf.	R-88-4.99K
R433	1K, 1%, 1/8W, Mtf.	R-88-1K
R434	22.2K, 0.1%, 1.10W, Mtf.	R-263-22.2K
R435	200 ohm, 0.1%, 1/10W, WW	R-291-200
R436	1K ohm, 1%, 2W, ww	R-290-1K
U401	Dual Op Amp	30475A
U402	Quad Comparator	IC-219
U403	Quad Comparator	IC-219
U404	Selected, Int. Circuit	30154
U405	Dual Op Amp	30477
U406	Selected, Int. Circuit	30167
VR401	Zener Diode 6.2V	DZ-48
VR402	Zener Diode 6.2V	DZ-48
VR403	Zener Diode 6.4V	DZ-60
VR404	Zener Diode 6.4V	DZ-60
VR405	Zener Diode 4.7V	DZ-67
VR406	Zener Diode 4.7V	DZ-67

* Followed by part description

** Selected at factory.

TABLE 6-4
Replaceable Mechanical Parts

Keithley Part No.	Description	Quantity
BOTTOM COVER		
30541	Bottom Cover	1
30544	Tilt Bail	1
FA-143	Drive Pin	1
FE-14	Foot	4
TOP COVER		
30540	Top Cover	1
TP-8-1	Foam	1
617-322	Shield	1
FRONT PANEL		
30539	Front Panel	1
30589	Front Panel Overlay	1
BP-11-0	Binding Post (Black)	1
BP-11-2	Binding Post (Red)	1
181-303-1	Shield	1
REAR PANEL		
30596	Rear Panel	1
BP-11-0	Binding Post (Black)	1
BP-11-2	Binding Post (Red)	1
FH-24	Fuse Carrier Body	1
FH-25	Fuse Carrier	1
MC-77	Serial No. Label	1
CS-254	AC Connector	1

TABLE 6-5
Cross Reference of Manufacturers

MFR. CODE	NAME AND ADDRESS	FEDERAL SUPPLY CODE	MFR. CODE	NAME AND ADDRESS	FEDERAL SUPPLY CODE
A-B	Allen-Bradley Corp. Milwaukee, WI 53204	01121	GRH	Grayhill, Inc. La Grange, IL 60525	81073
A-D	Analog Devices, Inc. Norwood, MA 02026	24355	H-P	Hewlett-Packard Co. Palo Alto, CA 94304	50444
ACI	American Components, Inc. Conshohocken, PA 19423	14298	INT	Intersil, Inc. Cupertino, CA 95014	32293
AMP	Amphenol Broadview, IL 60153	02660	ITT	ITT Semiconductor Lawrence, MA 01841	15238
BOM	Bomar Crystal Co. Middlesex, NJ 08846	73188	K & M	K & M Electronics Co. Minneapolis, MN 55435	
BRN	Bourns, Inc. Riverside, CA 92507	80294	K-I	Keithley Instruments, Inc. Cleveland, OH 44139	80164
C-I	Components, Inc. Biddeford, ME 04005	06751	L-F	Little Fuse, Inc. Des Plaines, IL 60016	75915
C & K	C & K Components, Inc. Watertown, MA 02158	09353	MAL	Mallory Indianapolis, IN 46206	90201
CAD	Caddock Riverside, CA 92507	19647	MEP	Mepco, Inc. Morristown, NJ 07960	80031
CLB	Centralab Division Milwaukee, WI 53201	71590	MMM	3M Company St. Paul, MN 55101	
COC	Corcom Chicago, IL 60639	05245	MOL	Molex Downers Grove, IL 60515	27264
COT	Coto-Coil Co., Inc. Providence, RI 02905	71707	MON	Monsanto St. Louis, MO 63122	76541
COW	Continental Wirt Warminster, PA	79727	MOT	Motorola Semi. Products Inc. Phoenix, AZ 85008	04713
CTS	CTS Corporation Elkhart, IN 46514	71450	MUR	Murata Corp. of America Elmsford, NY 10523	51406
DLE	Dale Electronics Columbus, NE 68601	91637	NAT	National Semi. Corp. Santa Clara, CA 94086	27014
ECI	Electro-Cube, Inc. San Gabriel, CA 91776	14752	NFC	NFC Microcomputer, Inc. Lexington, MA 02173	25088
EDI	Electronic Devices, Inc. Yonkers, NY 10710	83701	NIC	Nichicon Corp.. Chicago, IL 60645	18324
EMC	EMC Industried, Inc. Hatboro, PA 19040	50417	NYT	Nytronics Components Group Darlington, SC 29532	83125
ERI	Erie Technological Prod. Erie, PA 16512	72982	PAT	Pattison Supply Co. Cleveland, OH 44125	15818
F-I	Fairchild Instruments Mountain View, CA 94043	07263	POM	Pomona Electric Pomona, CA 91766	05276
G-E	General Electric Co. Syracuse, NY 13201	03508	PRP	Precision Resistive Products Mediapolis, IA 53237	

TABLE 6-5
Cross Reference of Manufacturers

MFR. CODE	NAME AND ADDRESS	FEDERAL SUPPLY CODE	
RCA	RCA Corporation Nashville, TN 37207	02734	
RIC	Richey Nashville, TN 37207	29309	
SCH	Schuster Electric Co. Cincinnati, OH 45242		
SIE	Siemens Corp. Iselin, NJ 08830	25088	
SIG	Sigmetics Corp. Sunnyvale, CA 94086	18324	
SPG	Sprague Electric Co. Visalia, CA 93278	14659	
SUP	Superior Electric Bristol, CT 06010	58474	
SYN	Synertek Santa Clara, CA 95051		
T-I	Texas Instruments, Inc. Dallas, TX 75231	01295	
TEL	Teledyne Mountain View, Ca 94040	15818	
TRW	TRW Electric Components IRC Boone, NC 28607	11502	
UCC	United Chemi-Con Inc. Rosemont, IL 60018		
VIC	Victoreen Instruments Co. Cleveland, OH 44103	63060	

Table 6-6
Parts List Additions

Circuit Desig.	Description	Schematic Dwg. No. and Location	PC Board Item No. and Location	Keithley Part No.
L301	Choke (Rear Panel Assembly)	30585/A1	PC-529	CH-29
FL101	Line Filter	30583/A4		LF-2
L102	Choke	30583/D5	PC-531:224/G6	CH-29
J1011	Pin	30585/A1	PC-529:129/B1	CS-357
J1012	Pin	30585/A2	PC-529:130/A1	CS-463
—	Connector	30586	PC-526:34/C3	CS-339-3
VR405	Zener Diode	30586/A1	PC-526:120/D3	DZ-67
VR406	Zener Diode	30586/A2	PC-526:121/D3	DZ-67
U404	Integrated Circuit	30586/D1	PC-526:110/C3	30154
U406	Integrated Circuit	30586/D5	PC-526:112/C3	30167

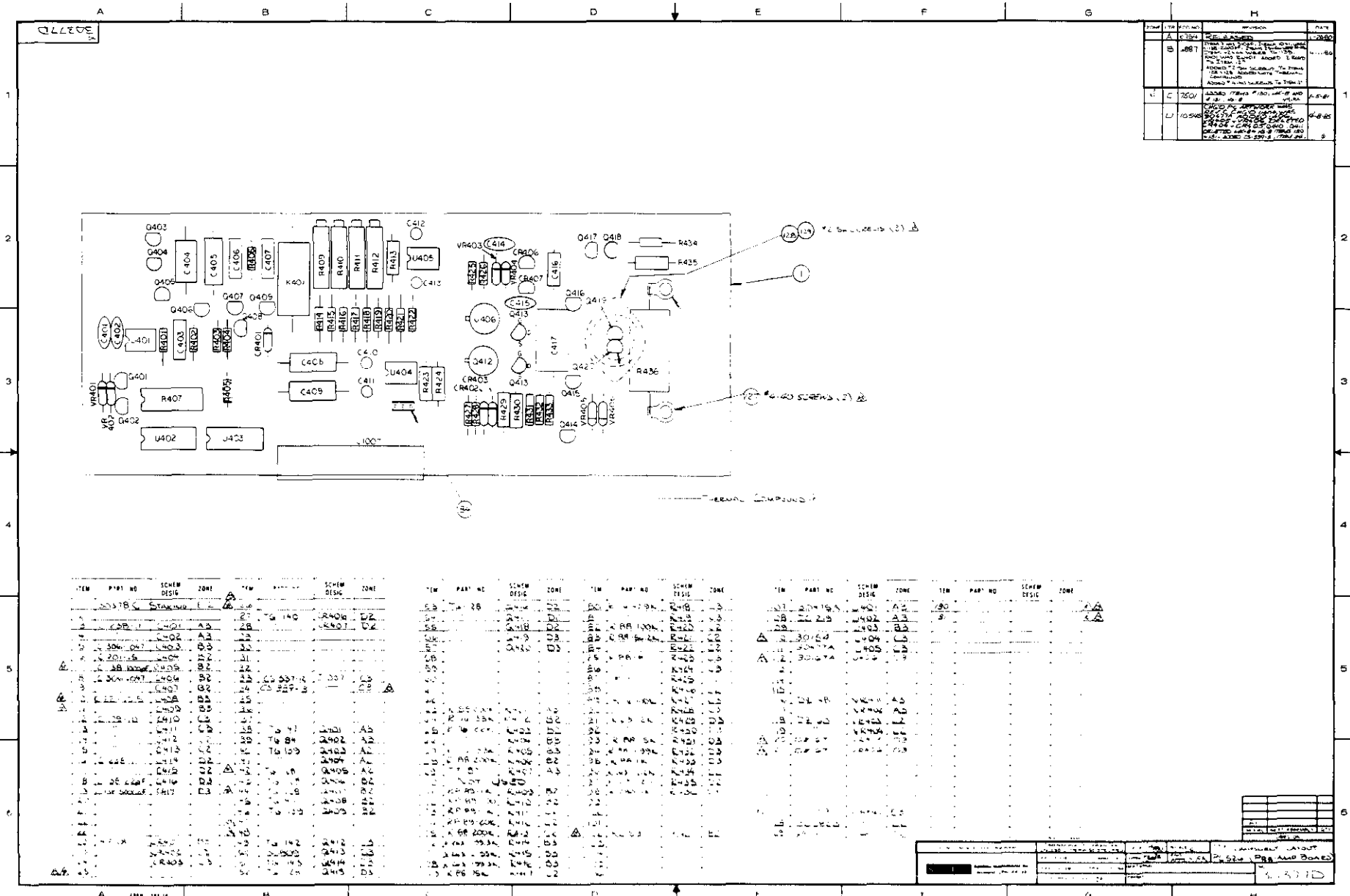
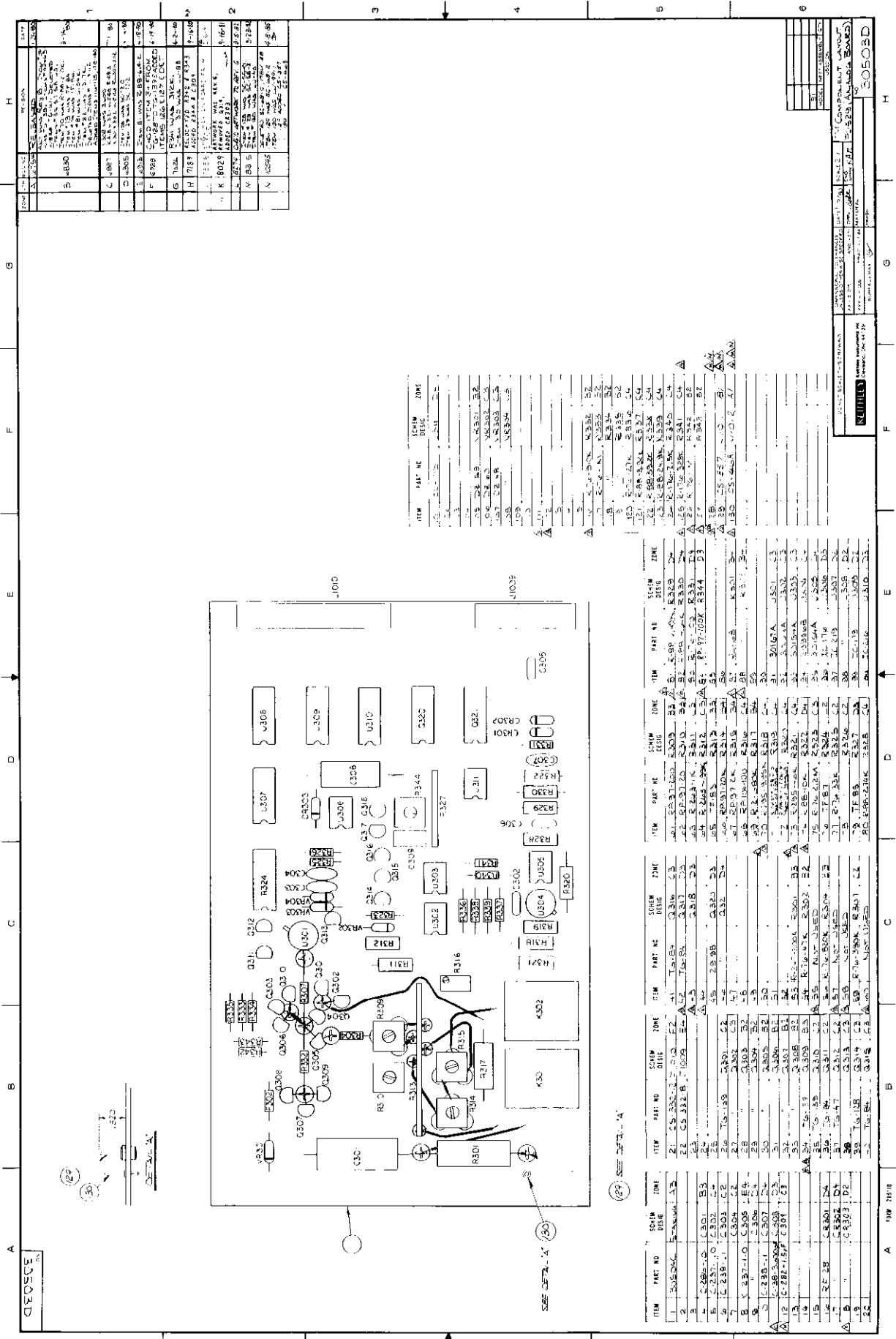

Figure 6-1. Nanovolt Preamp PC-526, Component Location Diagram, Dwg. No. 30377D



ITEM	PART NO	SCHEM DESIGN	QUANTITY	REASON	DATE
1	30503D	PC-529	1	REVISION	1-1-68
2	30503D	PC-529	1	REVISION	1-1-68
3	30503D	PC-529	1	REVISION	1-1-68
4	30503D	PC-529	1	REVISION	1-1-68
5	30503D	PC-529	1	REVISION	1-1-68
6	30503D	PC-529	1	REVISION	1-1-68

ITEM	PART NO	SCHEM DESIGN	QUANTITY	REASON	DATE
1	30503D	PC-529	1	REVISION	1-1-68
2	30503D	PC-529	1	REVISION	1-1-68
3	30503D	PC-529	1	REVISION	1-1-68
4	30503D	PC-529	1	REVISION	1-1-68
5	30503D	PC-529	1	REVISION	1-1-68
6	30503D	PC-529	1	REVISION	1-1-68

ITEM	PART NO	SCHEM DESIGN	QUANTITY	REASON	DATE
1	30503D	PC-529	1	REVISION	1-1-68
2	30503D	PC-529	1	REVISION	1-1-68
3	30503D	PC-529	1	REVISION	1-1-68
4	30503D	PC-529	1	REVISION	1-1-68
5	30503D	PC-529	1	REVISION	1-1-68
6	30503D	PC-529	1	REVISION	1-1-68

Figure 6-2. Analog Board PC-529, Component Location Diagram, Dwg. No. 30503D

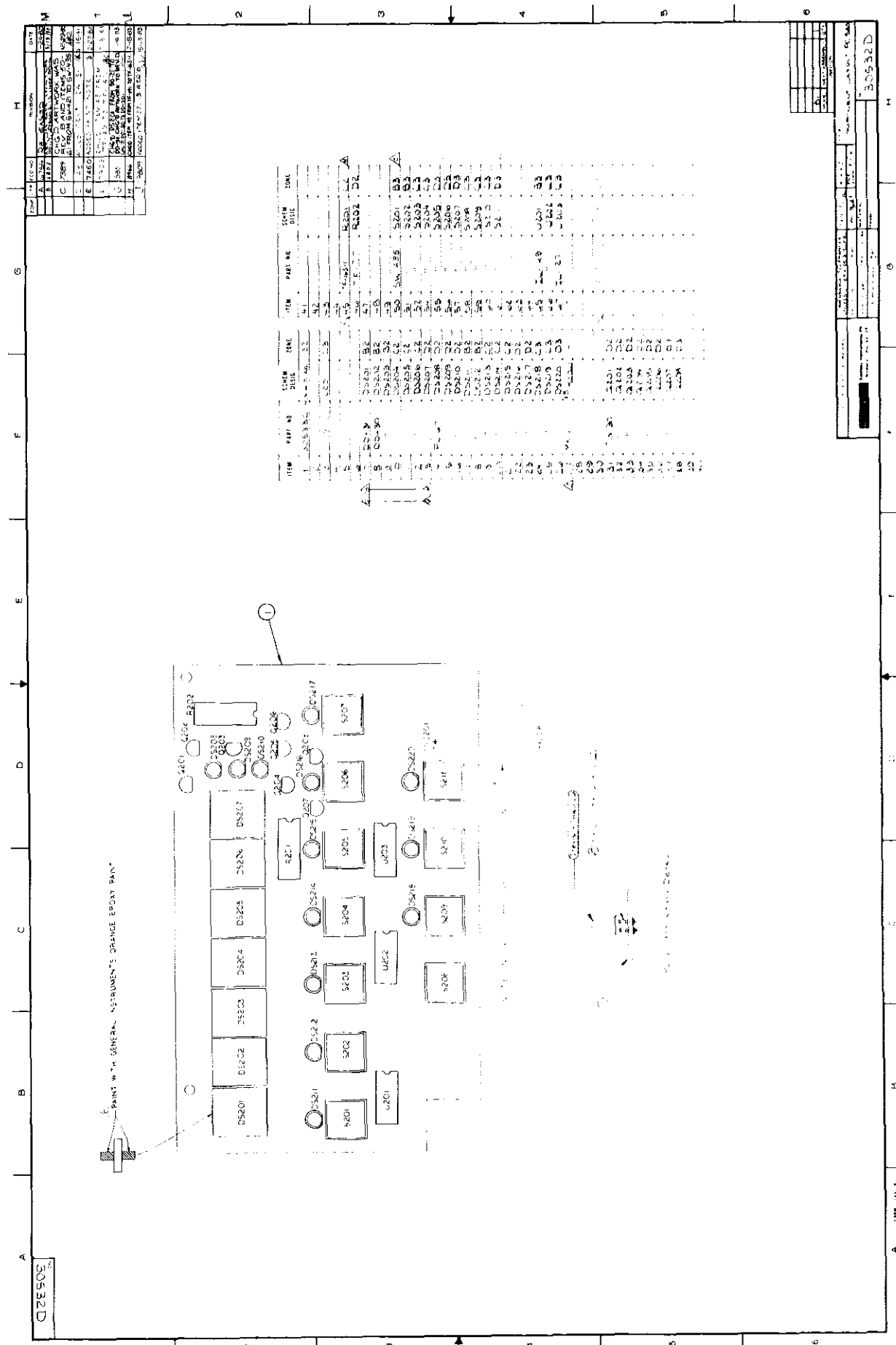

Figure 6-3. Display Board PC-530, Component Location Diagram, Dwg. No. 30532D

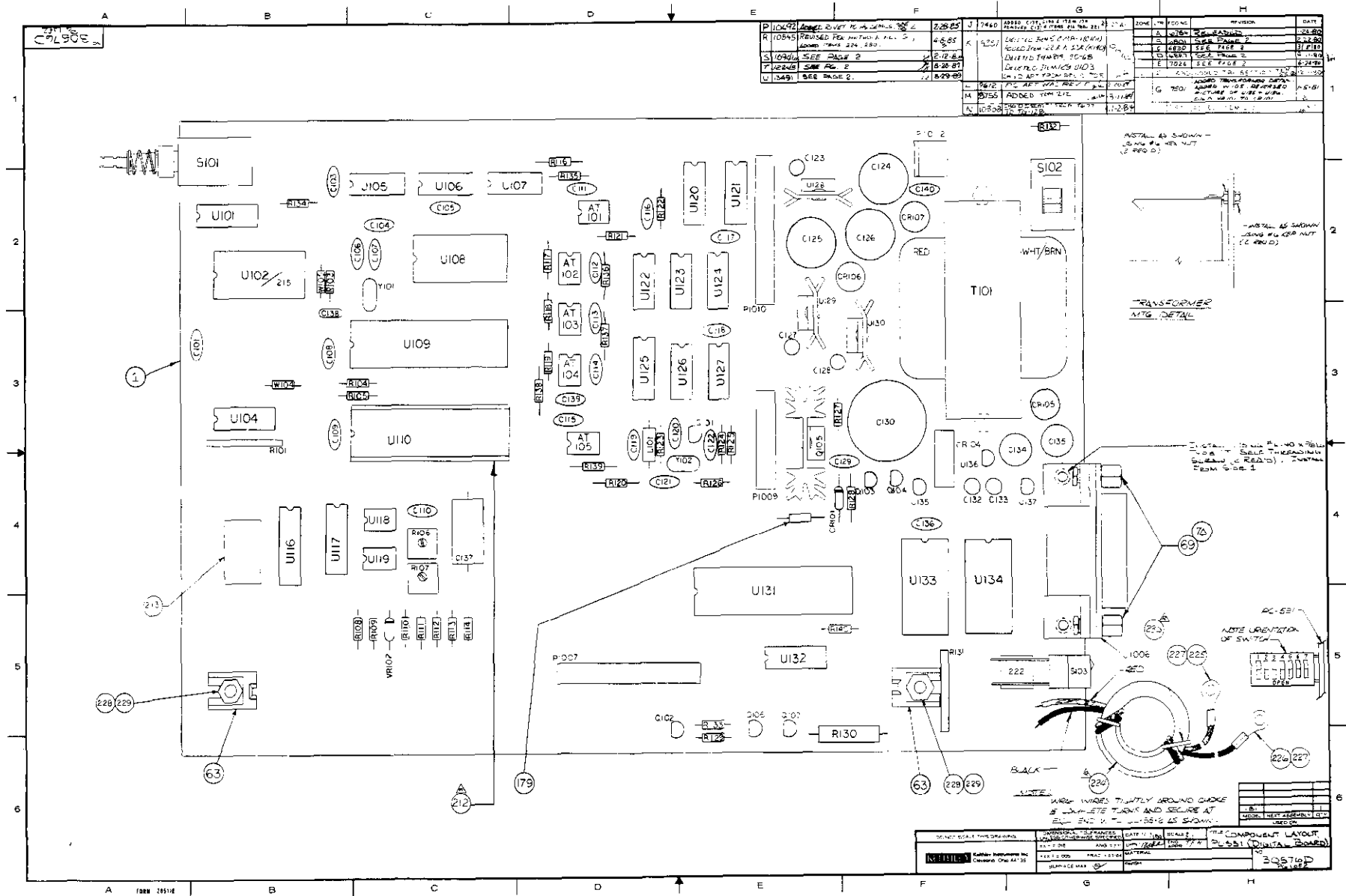
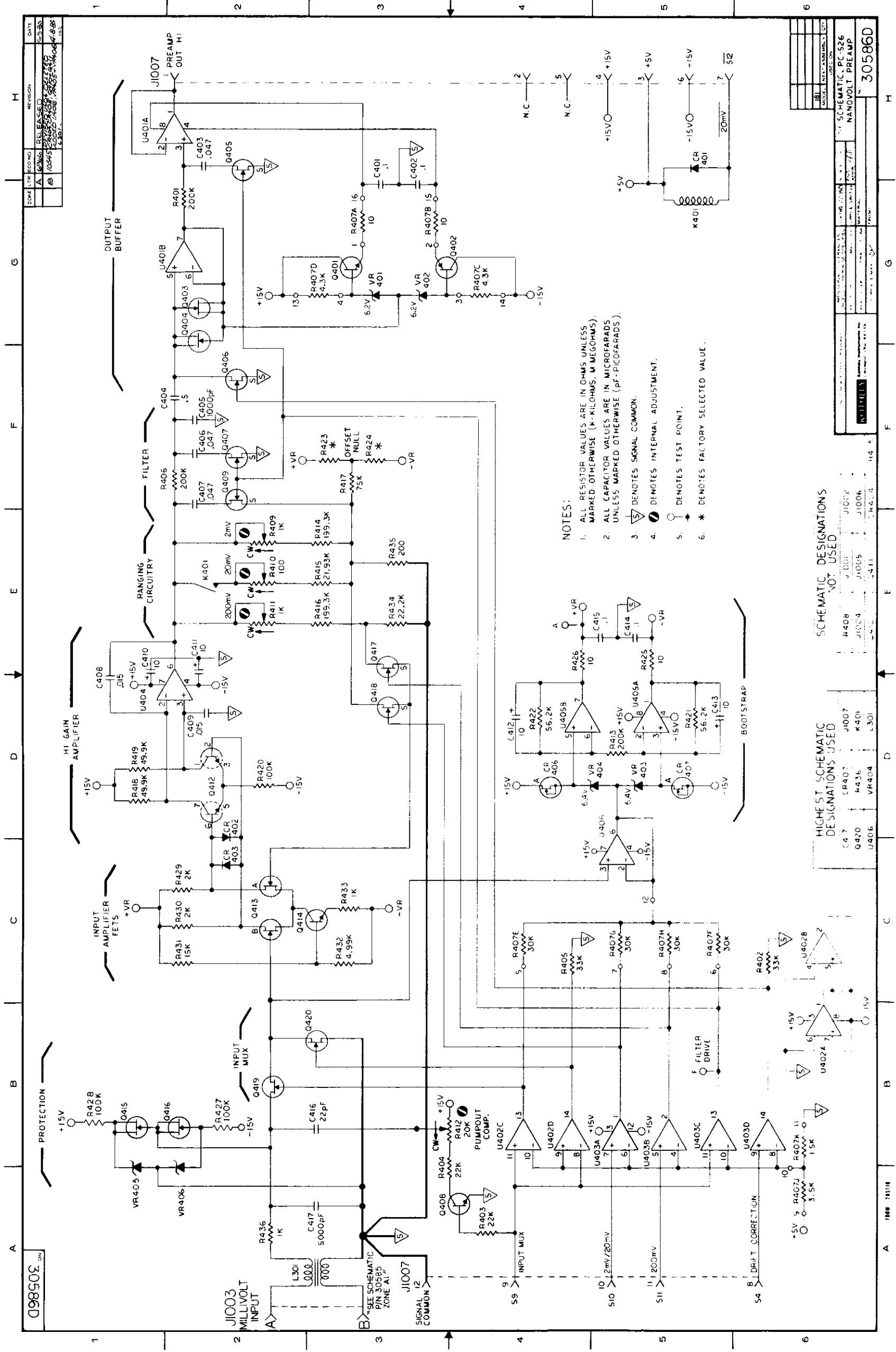

Figure 6-4. Digital Board PC-531, Component Location Diagram Dwg. No. 30576D



- NOTES:
1. ALL RESISTOR VALUES ARE IN OHMS UNLESS MARKED OTHERWISE (K-KILOHMS, M-MEGOHMS).
 2. ALL CAPACITOR VALUES ARE IN MICROFARADS UNLESS MARKED OTHERWISE (PF-PICOFARADS).
 3. ∇ DENOTES SIGNAL COMMON.
 4. ∇ DENOTES INTERNAL ADJUSTMENT.
 5. \odot DENOTES TEST POINT.
 6. \star DENOTES FACTORY SELECTED VALUE.

HIGHEST SCHEMATIC DESIGNATIONS USED		SCHEMATIC DESIGNATIONS NOT USED	
C47	U407	R408	J1002
Q470	U406	R410	J1004
U407	U403	R411	J1005
		R412	J1006
		R413	J1007
		R414	J1008
		R415	J1009
		R416	J1010
		R417	J1011
		R418	J1012
		R419	J1013
		R420	J1014
		R421	J1015
		R422	J1016
		R423	J1017
		R424	J1018
		R425	J1019
		R426	J1020
		R427	J1021
		R428	J1022
		R429	J1023
		R430	J1024
		R431	J1025
		R432	J1026
		R433	J1027
		R434	J1028
		R435	J1029
		R436	J1030
		R437	J1031
		R438	J1032
		R439	J1033
		R440	J1034
		R441	J1035
		R442	J1036
		R443	J1037
		R444	J1038
		R445	J1039
		R446	J1040
		R447	J1041
		R448	J1042
		R449	J1043
		R450	J1044
		R451	J1045
		R452	J1046
		R453	J1047
		R454	J1048
		R455	J1049
		R456	J1050
		R457	J1051
		R458	J1052
		R459	J1053
		R460	J1054
		R461	J1055
		R462	J1056
		R463	J1057
		R464	J1058
		R465	J1059
		R466	J1060
		R467	J1061
		R468	J1062
		R469	J1063
		R470	J1064
		R471	J1065
		R472	J1066
		R473	J1067
		R474	J1068
		R475	J1069
		R476	J1070
		R477	J1071
		R478	J1072
		R479	J1073
		R480	J1074
		R481	J1075
		R482	J1076
		R483	J1077
		R484	J1078
		R485	J1079
		R486	J1080
		R487	J1081
		R488	J1082
		R489	J1083
		R490	J1084
		R491	J1085
		R492	J1086
		R493	J1087
		R494	J1088
		R495	J1089
		R496	J1090
		R497	J1091
		R498	J1092
		R499	J1093
		R500	J1094
		R501	J1095
		R502	J1096
		R503	J1097
		R504	J1098
		R505	J1099
		R506	J1100
		R507	J1101
		R508	J1102
		R509	J1103
		R510	J1104
		R511	J1105
		R512	J1106
		R513	J1107
		R514	J1108
		R515	J1109
		R516	J1110
		R517	J1111
		R518	J1112
		R519	J1113
		R520	J1114
		R521	J1115
		R522	J1116
		R523	J1117
		R524	J1118
		R525	J1119
		R526	J1120
		R527	J1121
		R528	J1122
		R529	J1123
		R530	J1124
		R531	J1125
		R532	J1126
		R533	J1127
		R534	J1128
		R535	J1129
		R536	J1130
		R537	J1131
		R538	J1132
		R539	J1133
		R540	J1134
		R541	J1135
		R542	J1136
		R543	J1137
		R544	J1138
		R545	J1139
		R546	J1140
		R547	J1141
		R548	J1142
		R549	J1143
		R550	J1144
		R551	J1145
		R552	J1146
		R553	J1147
		R554	J1148
		R555	J1149
		R556	J1150
		R557	J1151
		R558	J1152
		R559	J1153
		R560	J1154
		R561	J1155
		R562	J1156
		R563	J1157
		R564	J1158
		R565	J1159
		R566	J1160
		R567	J1161
		R568	J1162
		R569	J1163
		R570	J1164
		R571	J1165
		R572	J1166
		R573	J1167
		R574	J1168
		R575	J1169
		R576	J1170
		R577	J1171
		R578	J1172
		R579	J1173
		R580	J1174
		R581	J1175
		R582	J1176
		R583	J1177
		R584	J1178
		R585	J1179
		R586	J1180
		R587	J1181
		R588	J1182
		R589	J1183
		R590	J1184
		R591	J1185
		R592	J1186
		R593	J1187
		R594	J1188
		R595	J1189
		R596	J1190
		R597	J1191
		R598	J1192
		R599	J1193
		R600	J1194
		R601	J1195
		R602	J1196
		R603	J1197
		R604	J1198
		R605	J1199
		R606	J1200

Figure 6 5 Nanovolt Preamp PC 526, Schematic Diagram, Dwg No. 30586D

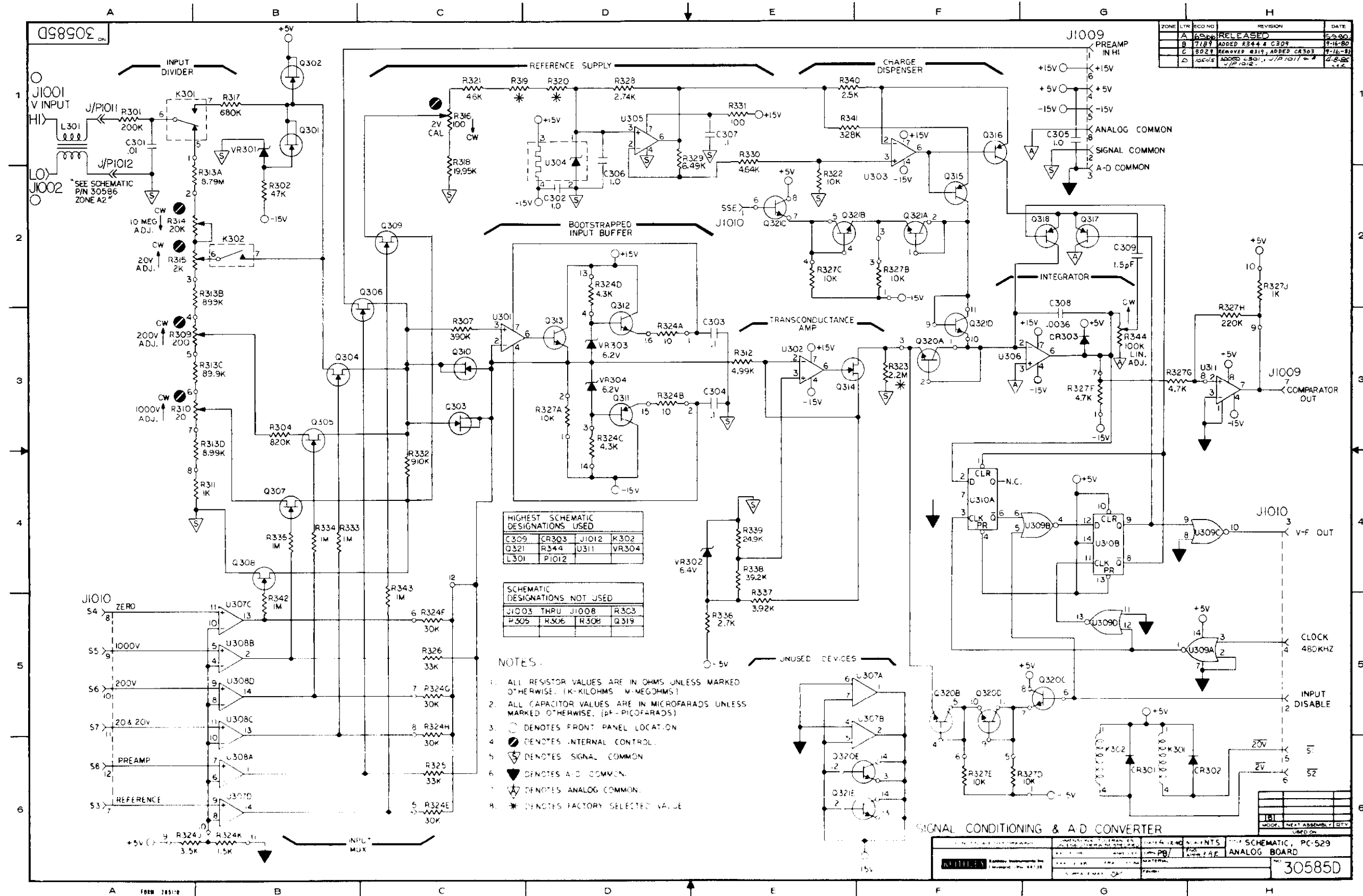

ZONE	LTR	ECO NO	REVISION	DATE
A	6	1	RELEASED	5-9-60
B	7	1	ADDED R344 & C309	7-16-60
C	8	2	REMOVED Q319, ADDED CR303	7-16-60
D	10	4	ADDED U301, U311, U312	4-8-60
			U302	5-6-60

Figure 6.6. Analog Board PC-529, Schematic Diagram, Dwg. No. 30585D

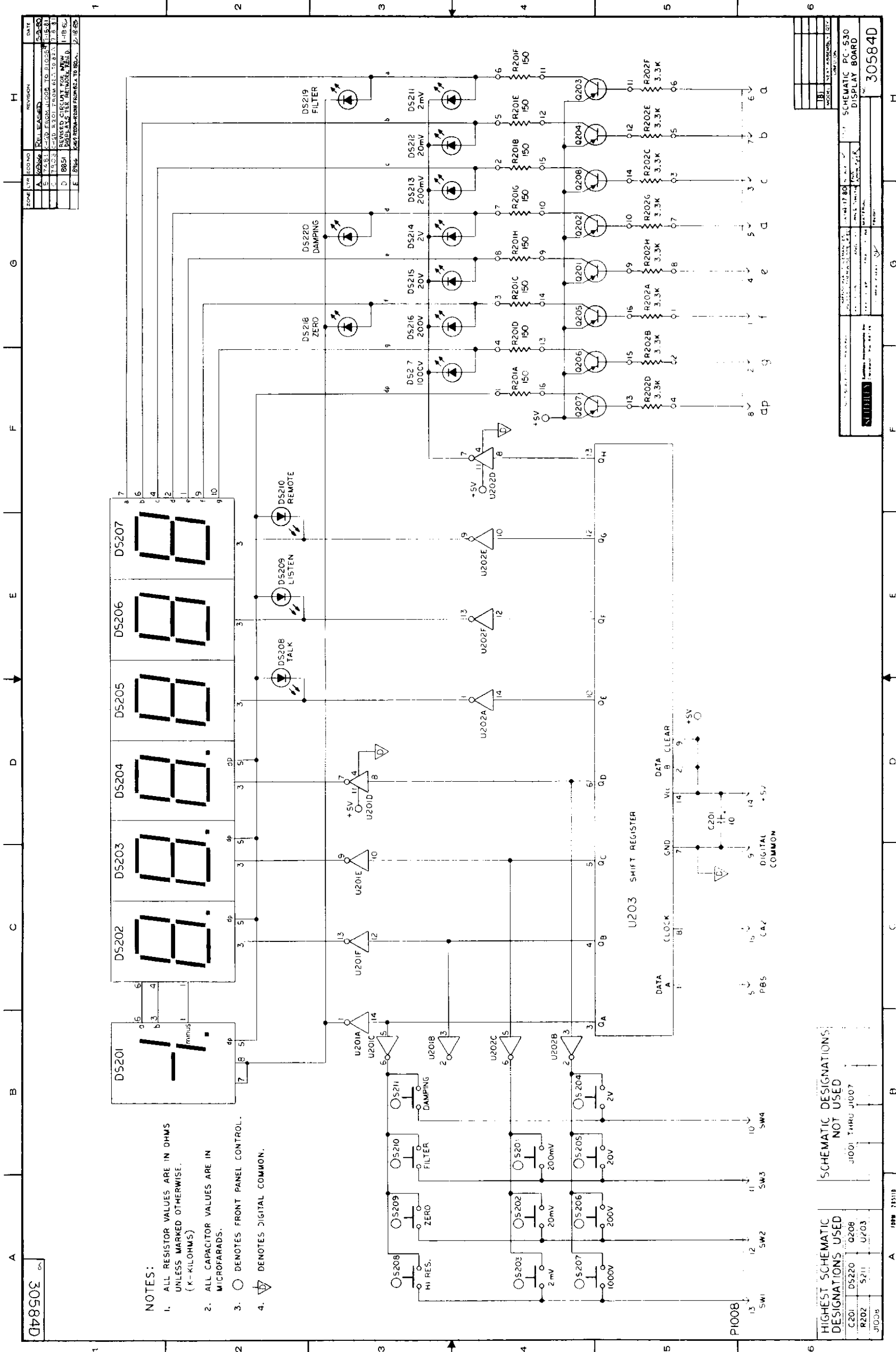

ZONE	TR	ECO NO	REVISION	DATE
A	1	7451	RELEASED	5-8-60
B	1	7451	REVISED FROM 7451 TO 7451A	5-8-60
C	1	7451	REVISED FROM 7451 TO 7451A	5-8-60
D	1	7451	REVISED FROM 7451 TO 7451A	5-8-60
E	1	7451	REVISED FROM 7451 TO 7451A	5-8-60

- NOTES:
1. ALL RESISTOR VALUES ARE IN OHMS UNLESS MARKED OTHERWISE. (K-KILOHMS)
 2. ALL CAPACITOR VALUES ARE IN MICROFARADS.
 3. ○ DENOTES FRONT PANEL CONTROL.
 4. ▽ DENOTES DIGITAL COMMON.

30584D		SCHEMATIC DESIGNATIONS NOT USED	
HIGHEST SCHEMATIC DESIGNATIONS USED	C201 DS220	Q208	J1001 T1MHU J1007
	R202	S211	U203
J1005			

30584D		SCHEMATIC PC-530 DISPLAY BOARD	
DATE		REVISED	
BY		BY	
CHECKED		CHECKED	
APPROVED		APPROVED	

Figure 6-7 Display Board PC-530, Schematic Diagram, Dwg. No. 30584D

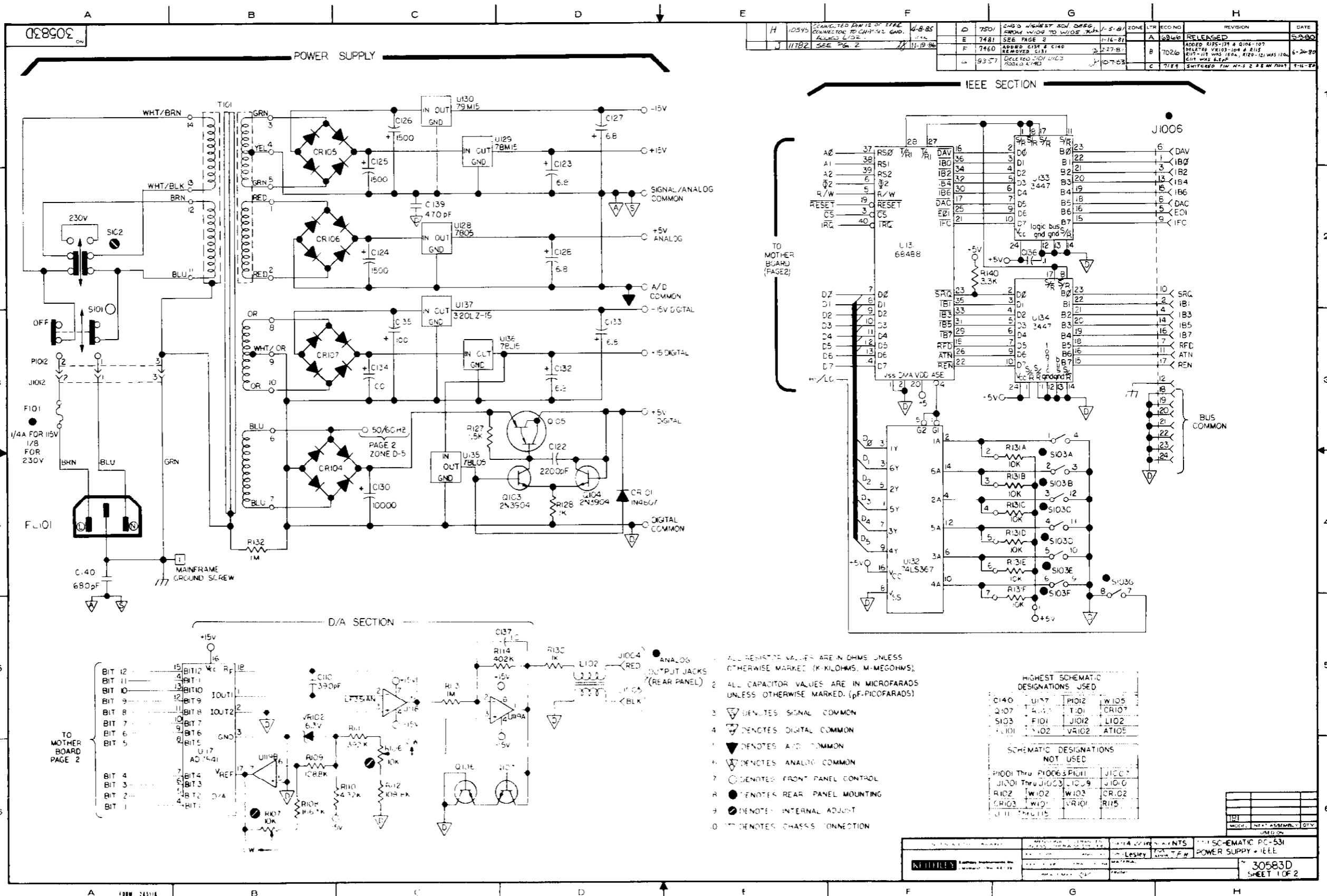

Figure 6-8 Digital Board PC-531, Schematic Diagram, Dwg. No. 30583D

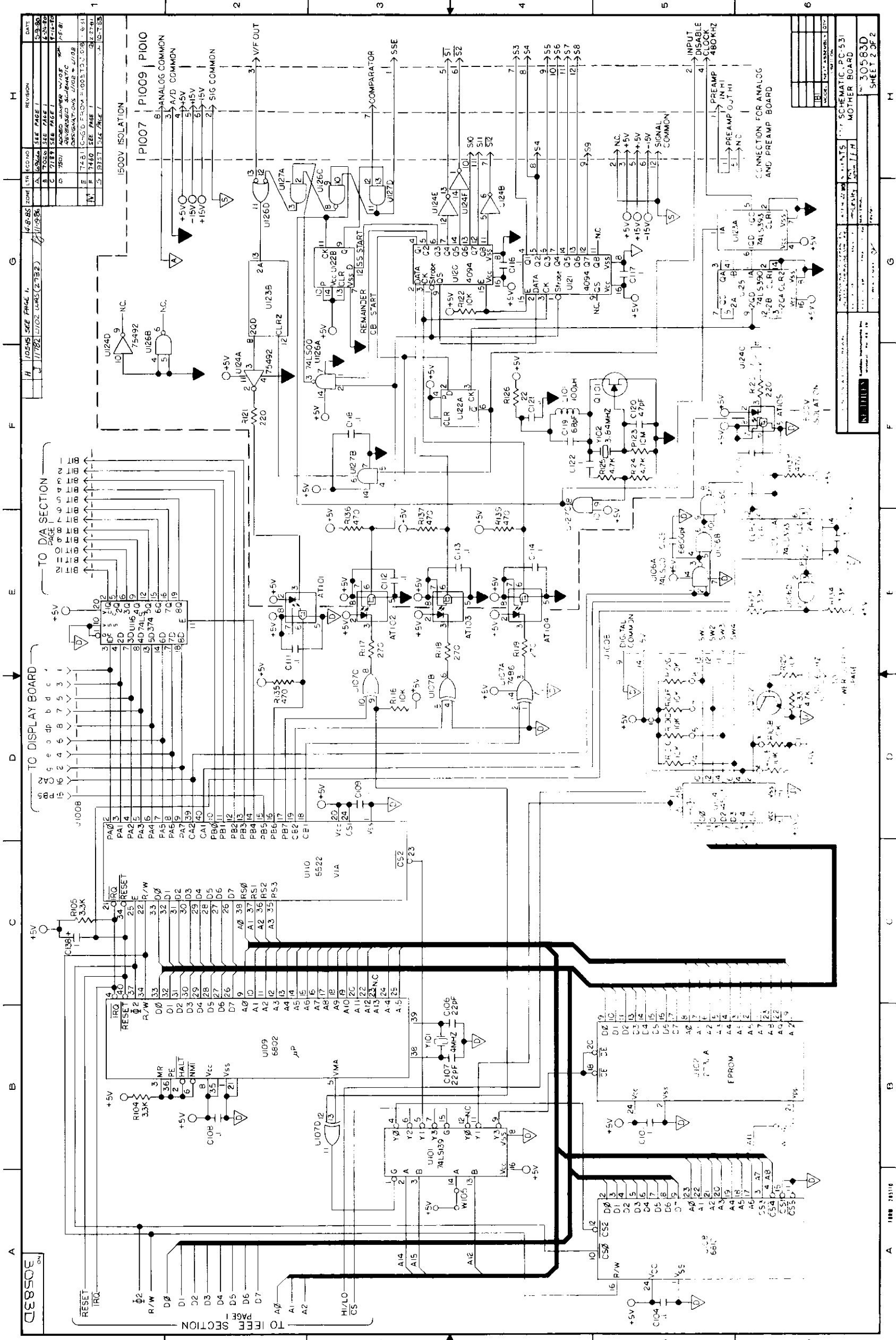

Figure 6.8 Digital Board PC 531, Schematic Diagram, Dwg. No. 30583D

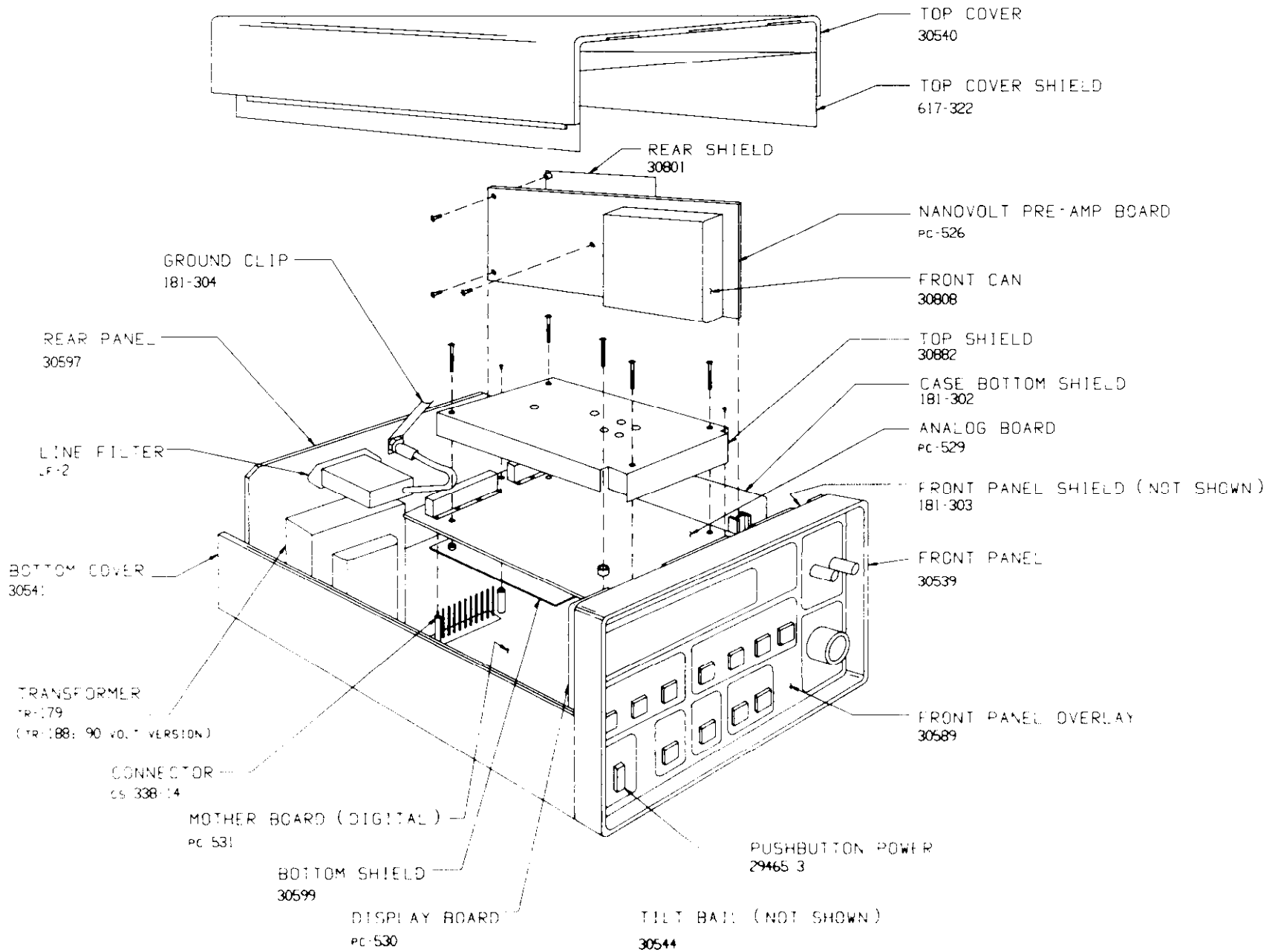

Figure 6-9. Mechanical Parts Locations

APPENDIX A

MODEL 181 IEEE ADDENDUM

The IEEE section in your Model 181 may have Texas Instruments SN75160s for U406 and U407 instead of the intended Motorola parts (MC3447s). The Texas Instruments parts are readily identifiable by removing the top cover and looking at the IEEE section located at the rear of the instrument. If two chips are on a separate PC board and wired into the original sockets on the mother board then they are the Texas Instruments SN75160s.

These parts (T.I. SN75160) DO NOT correspond to the original Schematic 30977D. Everything between the 68488 chip and the connector J1006 is different when the T.I SN75160s are installed. The result is the same, but the operation is accomplished differently than with the Motorola's MC3447s. Shown on the next page is the alternate configuration for the T.I. SN75160s.

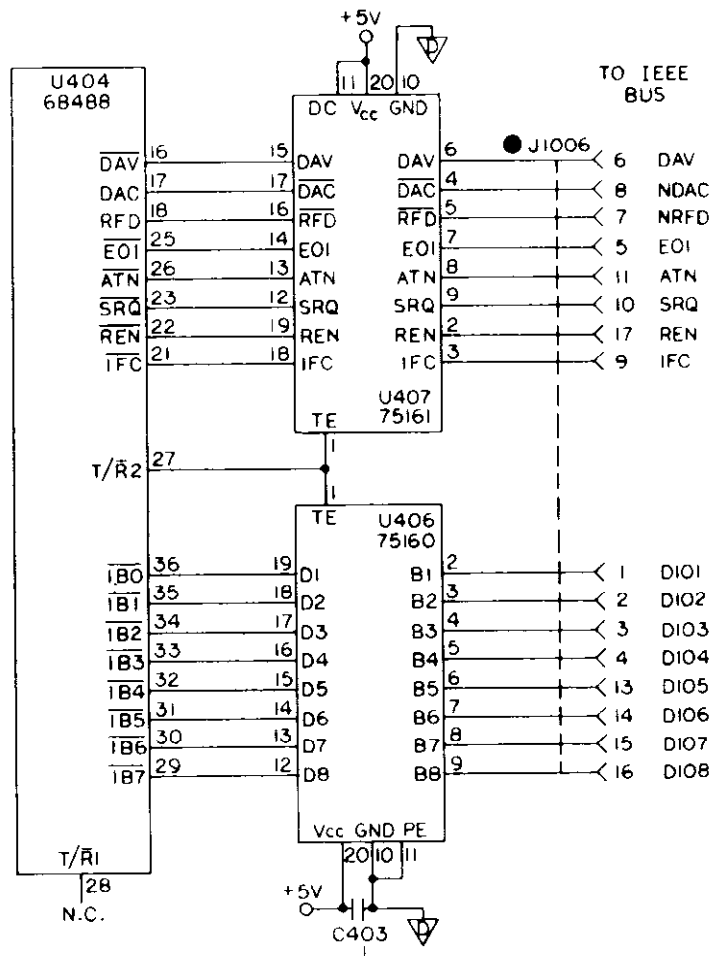

KEITHLEY INSTRUMENTS

SERVICE FORM

Model No. _____ Serial No. _____ Date _____

Name and Telephone No. _____

Company _____

List all control settings, describe problem and check boxes that apply to problem. _____

- | | | |
|--|--|--|
| <input type="checkbox"/> Intermittent | <input type="checkbox"/> Analog output follows display | <input type="checkbox"/> Particular range or function bad; specify _____ |
| <input type="checkbox"/> IEEE failure | <input type="checkbox"/> Obvious problem on power-up | <input type="checkbox"/> Batteries and fuses are OK |
| <input type="checkbox"/> Front panel operational | <input type="checkbox"/> All ranges or functions are bad | <input type="checkbox"/> Checked all cables |

Display or output (circle one)

- | | |
|-----------------------------------|--|
| <input type="checkbox"/> Drifts | <input type="checkbox"/> Unable to zero |
| <input type="checkbox"/> Unstable | <input type="checkbox"/> Will not read applied input |
| <input type="checkbox"/> Overload | |

Calibration only C of C required

Data required

(attach any additional sheets as necessary.)

Show a block diagram of your measurement system including all instruments connected (whether power is turned on or not). Also, describe signal source.

Where is the measurement being performed? (factory, controlled laboratory, out-of-doors, etc.)

What power line voltage is used? _____ Ambient Temperature? _____ °F

Relative humidity? _____ Other? _____

Any additional information. (If special modifications have been made by the user, please describe.) _____

Be sure to include your name and phone number on this service form.